

# Cartwheel Mobile Buffet

## Spec Sheet

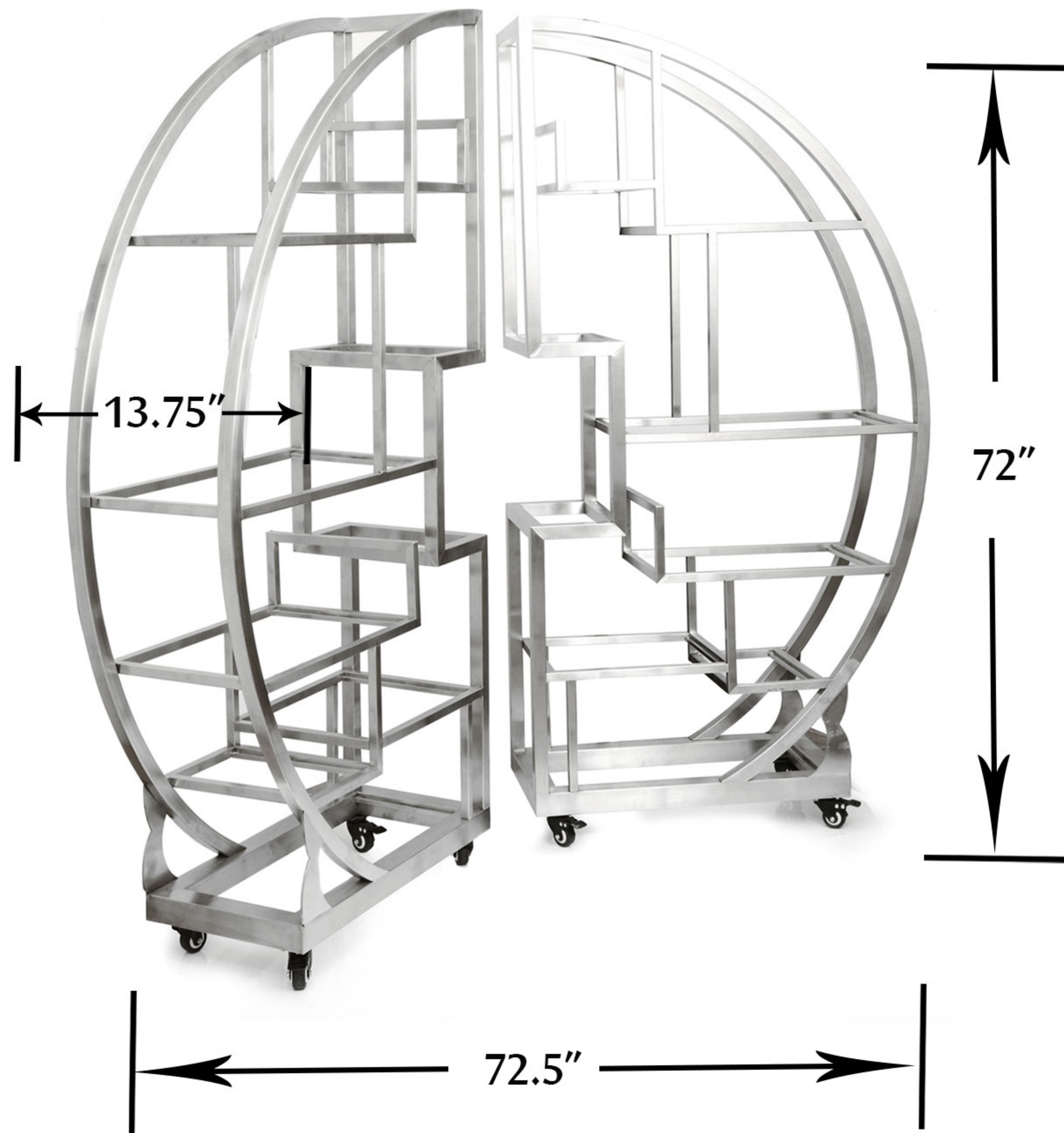

**ST1790 (Standard)**

**Cartwheel Set with Glass Shelves**

**AC1790**

**Cartwheel Set with Acrylic Shelves**

**AC1790BK**

**Cartwheel Set with Black Acrylic Shelves**

### Features :

Each Half Moon Display Designed with 7 Shelves

Stainless Steel Single Piece Construction

Shelves Firmly Set into Stainless Steel Frames

Locking Caster Wheels add Safety and Stability

Smooth Wheeling over all Surfaces

Double Sided Accesibility

XYLO Custom Finishes Available

### Includes 14 Shelves

2 of Each :

16 1/2" x 12 1/4"

7 1/2" x 12 1/4"

24 1/8" x 12 1/4"

19 1/8" x 12 1/4"

7 1/8" x 12 1/4"

23 5/8" x 9 3/4"

14 7/8" x 12 1/4"