

OPERATION MANUAL

HEAVY DUTY GAS CHARBROILER

MODELS
TH-QR-24
TH-QR-36
TH-QR-48

Includes
**INSTALLATION
USE & CARE**

FOR YOUR SAFETY

Do not store gasoline or other flammable liquids in the vicinity of this or any other appliance.

WARNING:

Improper installation, adjustment, alteration, service or maintenance can cause property damage, injury or death. Read the installation, operating and maintenance instructions thoroughly before installing or servicing this equipment.

IMPORTANT:

The purchaser of this equipment must post in a prominent location instructions to be followed in the event the user smells gas. This information shall be obtained by consulting the local gas supplier.

IMPORTANT: DO NOT DISCARD THIS MANUAL

This manual is considered to be part of the appliance and is to be given to the OWNER or MANAGER of the restaurant, or to the person responsible for TRAINING OPERATORS of this appliance. Additional manuals are available from your ICB dealer.

THIS MANUAL MUST BE READ AND UNDERSTOOD BY ALL PERSONS USING OR INSTALLING THIS APPLIANCE. Contact your ICB Dealer if you have any questions concerning installation, operation or maintenance of this equipment.



LIMITED WARRANTY STATEMENT

Unless otherwise specified, all commercial cooking equipment manufactured by ICB World Trade Corp. is warranted against defects in materials and workmanship for a period of one year from the date of original installation or 18 months from the date of shipment from our factory, whichever comes first, and is for the benefit of the original purchaser only.

THIS WARRANTY IS THE COMPLETE AND ONLY WARRANTY, EXPRESSED OR IMPLIED IN LAW OR IN FACT, INCLUDING BUT NOT LIMITED TO, WARRANTIES OF MERCHANTABILITY OR FITNESS FOR ANY PARTICULAR PURPOSE, AND/OR FOR DIRECT, INDIRECT OR CONSEQUENTIAL DAMAGES IN CONNECTION WITH ICB WORLD TRADE CORP. PRODUCTS. This warranty is void if it is determined that, upon inspection by an authorized service agency, the equipment has been modified, misused, misapplied, improperly installed, or damaged in transit or by fire, flood or act of God. It also does not apply if the serial nameplate has been removed, or if service is performed by unau-

thorized personnel. The prices charged by ICB World Trade Corp. for its products are based upon the limitations in this warranty. Seller's obligation under this warranty is limited to the repair of defects without charge by an ICB World Trade factory authorized service agency or one of its sub-service agencies. This service will be provided on customer's premises for non-portable models. Portable models (a device with a cord and plug) must be taken or shipped to the closest authorized service agency, transportation charges prepaid, for service. In addition to restrictions contained in this warranty, specific limitations are shown in the Service Policy and Procedure Guide.

This warranty is valid in the United States and Canada and void elsewhere. Please consult your classified telephone directory, your foodservice equipment dealer or phone ICB at (403) 243-5300 for information and other details concerning warranty.

SERVICE POLICY AND PROCEDURE GUIDE ADDITIONAL WARRANTY EXCLUSIONS

1. Resetting of safety thermostats, circuit breakers, over load protectors, and/or fuse replacements are **not** covered by this warranty unless warranted conditions are the cause.
2. All problems due to operation at **voltages or phase other than specified on equipment nameplates** are **not** covered by this warranty. Conversion to correct voltage and/or phase must be the customer's responsibility.
3. All problems due to **electrical connections not made in accordance with electrical code requirements and wiring diagrams** supplied with the equipment are **not** covered by this warranty.
4. Replacement of items **subject to normal wear**, to include such items as knobs, light bulbs; and, normal maintenance functions including adjustments of thermostats, adjustment of micro switches and replacement of fuses and indicating lights are **not** covered by warranty.
5. Damage to electrical cords and/or plug due to exposure to excessive heat are **not** covered by this warranty.
6. Full use, care, and maintenance instructions supplied with each machine. Noted maintenance and preventative maintenance items, such as servicing and cleaning schedules, are customer responsibility. Those miscellaneous adjustments noted are customer responsibility. Proper attention to preventative maintenance and scheduled maintenance procedures will prolong the life of the appliance.
7. Travel mileage is limited to **sixty (60) miles** from an Authorized Service Agency or one of its sub-service agencies.
8. All labor shall be performed during regular working hours. Overtime premium will be charged to the buyer.
9. All genuine ICB replacement parts are warranted for ninety (90) days from date of purchase on non-warranty equipment. This parts warranty is limited only to replacement of the defective part(s). **Any use of non-genuine ICB parts completely voids any warranty.**
10. Installation, labor, and job check-outs are **not** considered warranty and are thus **not** covered by this warranty.
11. Charges incurred by delays, waiting time or operating restrictions that hinder the service technician's ability to perform service are **not** covered by warranty. This includes institutional and correctional facilities.

SHIPPING DAMAGE CLAIM PROCEDURE

NOTE: For your protection, please note that equipment in this shipment was carefully inspected and packaged by skilled personnel before leaving the factory. Upon acceptance of this shipment, the transportation company assumes full responsibility for its safe delivery.

IF SHIPMENT ARRIVES DAMAGED:

1. **VISIBLE LOSS OR DAMAGE:** Be certain that any visible loss or damage is noted on the freight bill or express receipt, and that the note of loss or damage is signed by the delivery person.
2. **FILE CLAIM FOR DAMAGE IMMEDIATELY:** Regardless of the extent of the damage
3. **CONCEALED LOSS OR DAMAGE:** if damage is unnoticed until the merchandise is unpacked, notify the transportation company or carrier immediately, and file "CONCEALED DAMAGE" claim with them. This should be done within fifteen (15) days from the date the delivery was made to you. Be sure to retain the container for inspection.

ICB World Trade Corp. cannot assume liability for damage or loss incurred in transit. We will, however, at your request, supply you with the necessary documents to support your claim.

TABLE OF CONTENTS

ENGLISH

WARRANTY	xi
SPECIFICATIONS	1
FEATURES & OPERATING CONTROLS	2
PRECAUTIONS & GENERAL INFORMATION	3
AGENCY LISTING INFORMATION	3
INSTALLATION	4
OPERATION	8
CLEANING INSTRUCTIONS	10
TROUBLESHOOTING SUGGESTIONS	12
PARTS & SERVICE	13
CUSTOMER SERVICE DATA	13

INTRODUCTION

Thank You for purchasing this ICB World Trade Corp. appliance.

Proper installation, professional operation and consistent maintenance of this appliance will ensure that it gives you the very best performance and a long, economical service life.

This manual contains the information needed to properly install this appliance, and to use and care for the appliance in a manner which will ensure its optimum performance.

MODEL	STYLE	FUEL	MANIFOLD PRESSURE	B.T.U. per HOUR
TH-QR-24	4 Burners w/ Individual Control	Natural Gas	4.0" W.C.	100,000
		Propane (LP)	10" W.C.	
TH-QR-36	6 Burners w/ Individual Control	Natural Gas	4.0" W.C.	150,000
		Propane (LP)	10" W.C.	
TH-QR-48	8 Burners w/ Individual Control	Natural Gas	4.0" W.C.	200,000
		Propane (LP)	10" W.C.	

FEATURES & OPERATING CONTROLS

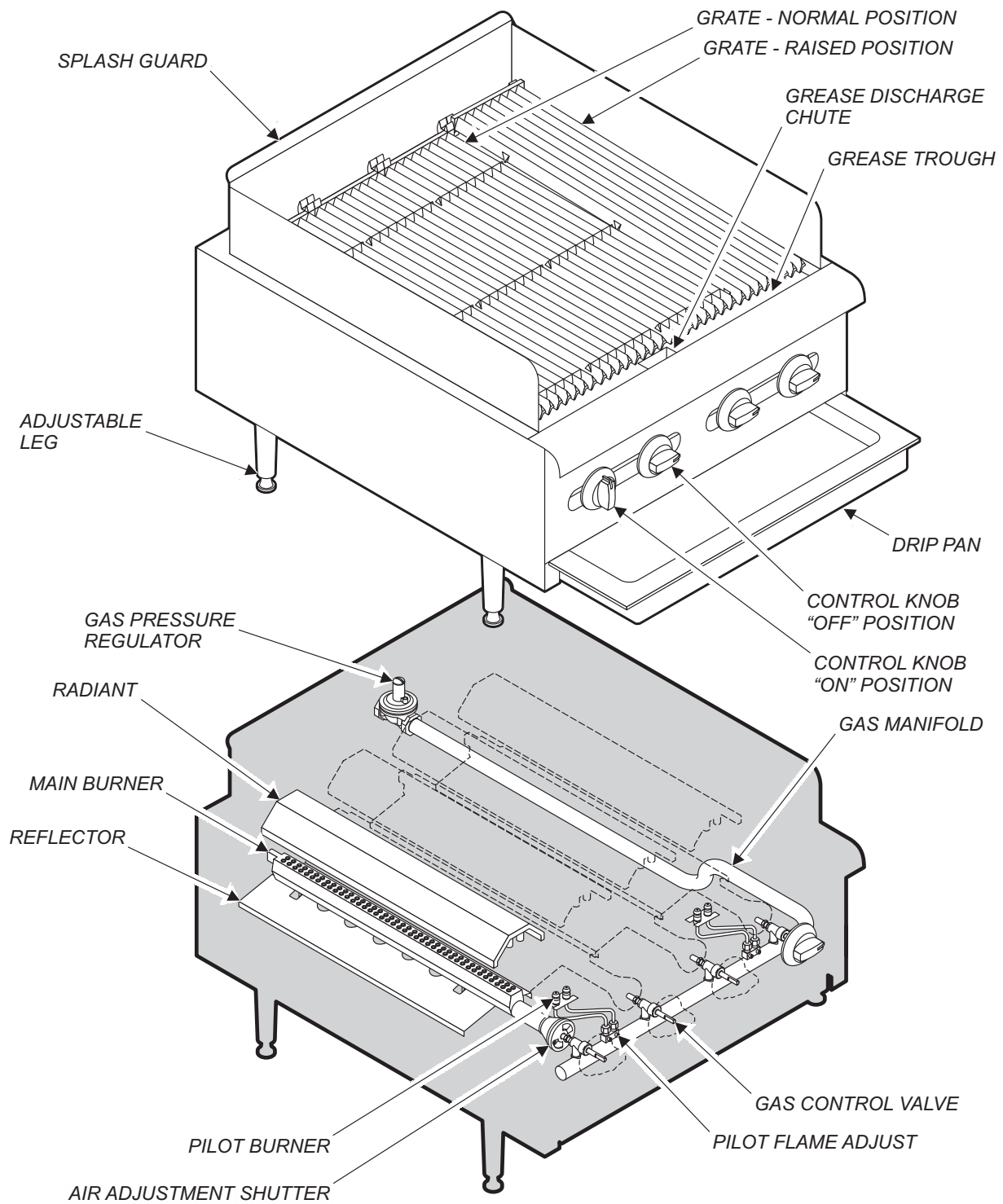

Fig. 1 Heavy Duty Gas Charbroiler - Features & Operating Controls

PRECAUTIONS AND GENERAL INFORMATION

This appliance is intended for use in commercial establishments only.

This appliance is intended to prepare food for human consumption. No other use is recommended or authorized by the manufacturer or its agents.

This appliance must be installed by a technician qualified and certified or licensed to install gas-fired equipment. A licensed technician must perform the initial start-up and adjustment of the appliance.

Operators of this appliance must be familiar with the appliance use, limitations and associated restrictions. Operating instructions must be read and understood by all persons using or installing this appliance.

Cleanliness of this appliance is essential to good sanitation. Read and follow all included cleaning instructions and schedules to ensure the safety of the food product.

DO NOT submerge appliance or burners in water. This appliance is not jet stream approved. DO NOT direct water jet or steam jet at this appliance, or at any control. DO NOT splash or pour water on, in or over any controls. DO NOT wash counter around this appliance with water jet. Burners which have become wet must be thoroughly dried before use.

Griddle surface will be very hot when in use. Contact will cause severe injury.

This appliance must be operated with the supplied 4" legs properly installed.

Do not operate this appliance if the smell of gas is present. Turn off all gas supply valves and move to a remote location to call your Authorized ICB Service Agent for service.

The technical content of this manual, including any parts breakdown illustrations and/or adjustment procedures, is intended for use by qualified technical personnel only.

Any procedure which requires the use of tools must be performed by a qualified technician.

This manual is considered to be a permanent part of the appliance.

This manual and all supplied instructions, diagrams, schematics, parts breakdown illustrations, notices and labels must remain with the appliance if it is sold or moved to another location.



WARNING: FIRE HAZARD

All servicing of the gas supply and combustion components of this appliance must be performed by a technician trained and certified in the maintenance of gas appliances. Improper servicing of gas equipment can result in fire and explosion.



CAUTION: HOT SURFACE

Exposed surfaces can be hot to the touch and may cause burns.

AGENCY LISTING INFORMATION

This appliance conforms to NSF Standard 4 for sanitation only if installed in accordance with the supplied *Installation Instructions* and maintained according to the instructions in this manual.

This appliance meets ANSI Z.83.11 specifications for gas-fired food service equipment.

This appliance is Canadian Standards Association design certified for gas operation.

INSTALLATION

NOTE: DO NOT discard the carton or other packing materials until you have inspected the appliance for hidden damage and tested it for proper operation. Refer to *SHIPPING DAMAGE CLAIM PROCEDURE* on the inside front cover of this manual.



**DANGER:
HEALTH
HAZARD**

This appliance must be properly ventilated. Failure to provide and maintain proper ventilation of exhaust gasses can result in severe injury or death.



**WARNING:
FIRE HAZARD**

Do not store gasoline or any other flammable or combustible material near this appliance. The open flame can cause such materials to ignite.

The area where the griddle is installed must be kept clear of combustibles and flammables. This includes mops, rags, grease, wrapping paper and electric cords.

NOTICE: Manufacturer's warranty on this charbroiler is in effect only when the griddle is installed in accordance with these instructions and local codes and ordinances or, in the absence of local codes, the National Fuel Gas Code, ANSI Z223.1 (current edition). The manufacturer of this griddle assumes no liability for any damage or injury resulting from failure to comply with this notice.

UNPACKING & INSPECTION

Carefully remove the appliance from the carton. Remove all protective plastic film, packing materials and accessories from the appliance before connecting performing any installation procedure.

Carefully read all instructions in this manual and the *Installation Instruction Sheet* packed with the appliance before starting any installation.

Read and understand all labels and diagrams attached to the appliance.

Carefully account for all components and accessories before discarding packing materials. Store all accessories in a convenient place for later use.

COMPONENTS

Grates (-QR-24, 4 ea.; -QR-36, 6 ea.; -QR-48, 8ea.)
Radiants (-QR-24, 4 ea.; -QR-36, 6 ea.; -QR-48, 8ea.)
Burner Assy. (-QR-24, 4 ea.; -QR-36, 6 ea.; -QR-48, 8ea.)
Adjustable Legs (set of 4)
Drip Tray
Wire Brush

SETUP

Setup the charbroiler only on a firm, level, non-combustible surface. Verify local codes for requirements. Concrete, tile, terrazzo or metal surfaces are recommended. Metal or tile over combustible material may not meet code for non-combustible surfaces.

Install the provided adjustable legs, one on each corner of the appliance, in the holes provided. Verify that the unit sits firmly ON ALL FOUR LEGS. With the adjustable legs, adjust as required to level the appliance. All four legs must be adjusted to firmly contact the countertop in order to prevent tipping.

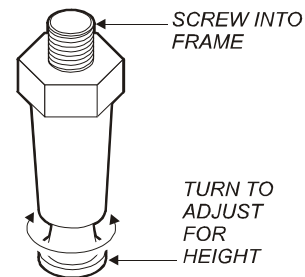

Adequate clearance for air openings in the cabinet must be provided. Refer to the *Installation Instruction Sheet* for required clearances. Maintain required clearances between the appliance and adjacent combustible surfaces.

The charbroiler must be installed in an area with sufficient make-up air for proper combustion, and must be installed such that the flow of combustion and ventilation air will not be obstructed.

When used with an exhaust fan, special precautions must be observed to avoid interference with the operation of the griddle, such as drafts and air starvation.

GAS APPLIANCE CODE COMPLIANCE

The installation of gas piping from the outlet side of the gas meter or service regulator to the charbroiler must be performed by a technician qualified and certified or licensed to install gas-fired equipment.

A licensed and qualified technician must perform the initial startup and adjustment of this appliance.

The installation of this gas-fired appliance must conform to local codes, or in the absence of such codes, with the current edition of National Fuel Gas Code ANSI Z223.1.

The installation of this gas-fired appliance must comply with applicable portions of NFPA 96 for ventilation. The current edition of NFPA 96 (*Standard for the Installation of Equipment for the Removal of Smoke and Grease Laden Vapors from Commercial Cooking Equipment*) specifies ventilation requirements to ensure the removal of exhaust gasses and products of combustion.

IT IS THE RESPONSIBILITY OF THE INSTALLER TO ENSURE THAT THIS GAS GRIDDLE INSTALLATION CONFORMS TO ALL APPLICABLE CODES AND ORDINANCES.

The venting of this appliance must not be obstructed, nor may such venting interfere with the flow of combustion air required for proper operation of the gas burners.

Additionally:

1. The gas supply line used to connect the appliance to the gas supply system must be black iron pipe, or other material as approved by local ordinance for gas piping.
2. Gas supply piping must be 3/4" inside diameter or greater.
3. Use pipe sealant made specifically for gas piping on all pipe joints. Apply sealant sparingly to the male threads only. Sealant must be resistant to the action of LP gas.
4. Verify that all supply piping is clean and free of obstructions, dirt, chips and pipe sealant compound prior to installation.
5. All pipe joints must be checked for leaks before lighting. Leak checks should be performed with a soap and water solution. **NEVER CHECK FOR LEAKS WITH AN OPEN FLAME.**



**DANGER:
FIRE AND
EXPLOSION
HAZARD**

NEVER use an open flame to check for gas leaks. Fire and explosion may result.



**WARNING:
RISK OF INJURY**

Installation procedures must be performed by a qualified technician with full knowledge of all applicable gas-fired appliance codes. Failure can result in personal injury and property damage.

IMPORTANT:

All pipe joints must be checked for leaks before lighting. Leak checks should be performed with a soap and water solution.

IMPORTANT:

Information on the construction and installation of ventilating hoods may be obtained from the current edition of NFPA 96 *Standard for the Installation of Equipment for the Removal of Smoke and Grease Laden Vapors from Commercial Cooking Equipment*. Copies of this standard are available from the Nation Fire Protection Assn.:

NFPA
1 Batterymarch Park
P.O. Box 9101
Quincy, MA 02269-9101

INSTALLATION (continued)



DANGER: FIRE AND EXPLOSION HAZARD

NEVER use an open flame to check for gas leaks. Fire and explosion may result.

IMPORTANT:

All pipe joints must be checked for leaks before lighting. Leak checks should be performed with a soap and water solution.



WARNING: FIRE HAZARD

This appliance is supplied with a gas pressure regulator. Failure to properly install the supplied regulator will result in an extremely hazardous condition.

Flow arrow stamped on body of regulator must point toward the griddle.

Vent hole must point UP.

IMPORTANT:

Verify fuel gas type. If the available fuel does not match the nameplate specification, exchange the appliance for the correct type.

IMPORTANT:

The appliance and its individual manual shutoff valve must be disconnected from supply system piping during any pressure testing of that system at pressures in excess of 1/2 p.s.i. (3.5 kPa).

Also, the appliance must be isolated from the gas supply piping system by closing its individual manual shutoff valve during any pressure testing of the gas supply piping at test pressures equal to or less than 1/2 p.s.i. (3.5 kPa).

INSTALLING THE GAS GRIDDLE

Refer to the nameplate. Verify the fuel type and pressure, which must match the nameplate specifications. Connecting the hotplate to the wrong fuel type and/or pressure will compromise the safety and/or performance of the appliance.

BE SURE TO MAINTAIN REQUIRED CLEARANCES TO COMBUSTIBLE SURFACES.

The appliance must be placed in its final operational position and leveled front-to-back and side-to-side, with a spirit level, prior to beginning the gas piping installation. Re-check the level of the unit at the conclusion of the gas piping installation.

Each gas appliance is supplied with a separate gas pressure regulator, which must be installed on the manifold pipe protruding from the rear of the griddle. Ensure that the regulator is installed such that the flow arrow stamped on the body of the regulator points toward the griddle. Failure to properly install the supplied regulator will result in an extremely hazardous condition.

A moisture trap (drip leg) consisting of a tee, 4" nipple pointing down, and cap must be installed upstream of the gas pressure regulator.

A manual gas shut-off valve may be required by local codes and is, in any case, strongly recommended. The shut-off valve must be installed between the gas supply piping and the gas pressure regulator.

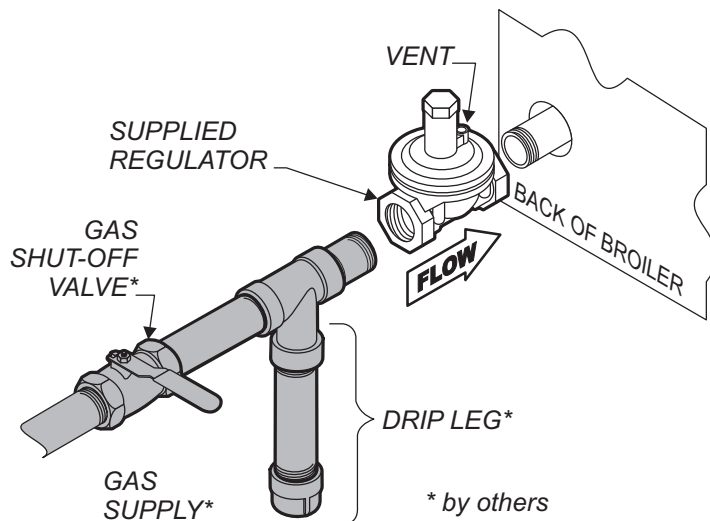

Fig. 2 Gas Supply Piping

It is the responsibility of the gas piping installer to identify the code requirement for a shut-off valve.

Shut-off valves, moisture trap and all associated piping must be supplied by the gas piping installer.

INSTALLATION (continued)

SET GAS PRESSURE:

Gas pressure regulator is factory set.

SET PILOT FLAME:

Remove all burner control knobs, then remove the front panel.
Remove grates.

The pilot adjustments are near the control valve for each set of burners.

Using a small, flat-blade screwdriver, turn the screw clockwise to decrease the flame size, or counter-clockwise to increase the flame size.

Adjust the pilot flame to 1/4" high. Test for operation: all sections of the burner must light without undue delay. Drafty conditions may require a higher flame to allow the pilot to remain lit.

Replace the grates, front panel and all knobs before returning the unit to service.

IMPORTANT:

Adjustments must be performed by a qualified technician only.

IMPORTANT:

The appliance is shipped from the factory equipped for natural gas and adjusted for sea level to 2000 feet elevation.

For conversion to LP / Propane, or for operation above 2000 feet elevation, contact your Authorized ICB Service Agency.

ADJUST BURNER FLAME:

Remove all burner control knobs, then remove the front panel.
Remove grates and radiants.

Turn an individual burner on.

Loosen the locking screw on the shutter.

Turn the shutter to admit more or less air as required. Adjust the air shutter until the flame is mostly blue in color.

Tighten the locking screw when finished. Replace tall grates and radiants, the front panel and all knobs before returning the unit to service.

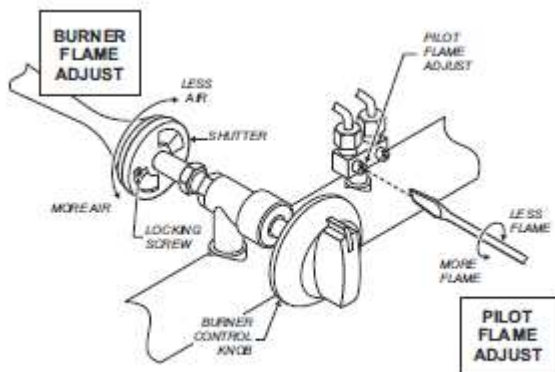

Fig. 3 Adjustments

OPERATION



**WARNING:
FIRE HAZARD**

IF YOU SMELL GAS:

- ❑ DO NOT try to light any appliance.
- ❑ DO NOT touch any electrical switch
- ❑ DO NOT use any telephone in your building.

In the event a gas odor is detected, shut down the unit at the main gas shut-off valve and contact your local gas supplier from a neighboring location.

Follow the instructions received from the gas supplier immediately and exactly.

GENERAL OPERATIONAL NOTES

Carefully read the description of the charbroiler operation on the specification sheet.

Do NOT use this appliance if it has been submerged in water. Call a qualified technician to examine the appliance and to service or replace any component which has been submerged. Burners which have been allowed to become wet must be thoroughly dried before use.

For initial startup, and any time the gas supply has been shut-off, it may take several minutes to light the pilot while air in the piping and manifolds is purged.

The burner control knobs must be turned by hand only. Never use tools to turn the control knob. If the knob will not turn by hand, DO NOT attempt to force or repair it. Contact your Authorized ICB Service Agency for repairs. Forced or improperly repaired valves pose the risk of fire and/or explosion.

Make sure burners, pilot burner and drip tray are properly installed before attempting to operate.

LIGHTING THE PILOT FLAME

Before lighting the pilot light, smell all around the appliance area for gas. Be sure to smell near floor level because some gas is heavier than air and will settle to the floor.

For initial startup, and any time the gas supply has been shut-off, it may take several minutes to light the pilot while air in the piping and manifolds is purged.

The pilot light must be lighted by hand:

Remove grates. Turn all control knobs to the full OFF position.

The pilot is located adjacent to the burner, and is accessible from the top of the unit.

Be sure the gas shut-off valve is ON and the appliance has had time for the air to be purged from the lines. Attempt to light the pilot every 15 seconds after the gas valve is turned on.

Light the pilot with a long match or fireplace lighter.

DO NOT use a cigarette lighter.

Reinstall grates

SHUT DOWN INSTRUCTIONS

Turn all burner knobs to *OFF*.

Turn all pilots *OFF*.

Turn the main gas supply *OFF*.

OPERATION

Inspect the unit for cleanliness before use. Clean as necessary: See *Cleaning Instructions*, page 10.

Be sure the pilot light is lit before operation. See *Lighting the Pilot Light*, page 8.

The burner control knobs must be turned by hand only. Never use tools to turn the control knob.

The control used in this gas griddle provides a continuous range of settings from OFF to ON.

Light the burner by turning the control knob to the ON position until fire forms completely in all sections of the burner. Set the control knob to the desired position. The setting can be readjusted at any time.

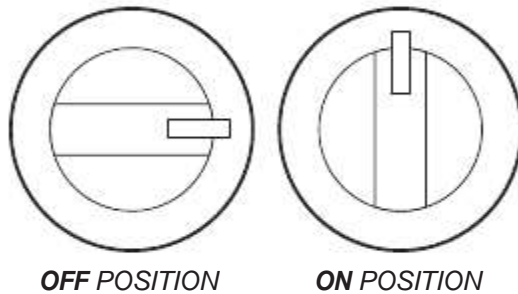

Fig. 4 Burner Control

Cooking Recommendations:

Save energy by turning the temperature control knob OFF any time the griddle is not in use. Gas burners provide full heat instantly, making it unnecessary to leave the unit on during intermittent use.

To decrease the amount of grease contacting the radiants, the grate may be raised. Invert the grate so that the rear grate hooks are at the bottom and the grate sits at a slight angle.

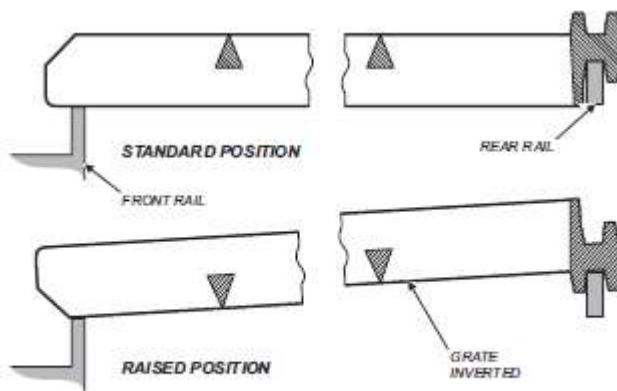

Fig. 5 Grate Positions

WARNING: FIRE HAZARD

NEVER attempt to force or repair a stuck control valve.

Contact your Authorized ICB Service Agency for repairs.

Forced or improperly repaired valves pose the risk of fire and/or explosion.

WARNING: FIRE AND EXPLOSION HAZARD

If the pilot light should be extinguished, turn off the gas shut-off valve.

Allow the appliance to vent for five minutes before attempting to re-light.

CAUTION: HOT SURFACE

Exposed surfaces can be hot to the touch and may cause burns.

CLEANING INSTRUCTIONS



WARNING: FIRE HAZARD

Shut off the gas supply valve before cleaning.



CAUTION: BURN HAZARD

Allow hotplate to cool completely before cleaning.

IMPORTANT: DO NOT spill or pour water into controls.

DO NOT submerge cabinet in water. Damage to internal components will occur. Damage to internal components from water damage is NOT covered by warranty.

DO NOT allow gas control valves, main burners or pilot burners to become wet. Never pour or splash water into cabinet. Wet burners must be thoroughly dried before use.

DO NOT use steel wool or metal scouring pads to clean cabinet or grease tray.

Good sanitation is vital to the quality of the final food product. Be sure to clean in all corners and crevices where grease and other cooking debris can accumulate.

PREPARATION

Turn both temperature control knobs OFF.
Allow broiler to cool completely.
Disconnect broiler from electric power.

FREQUENCY

Daily.

TOOLS

Steel Brush with scraper
Plastic Scouring Pad, Soft-Bristled Fiber Brush
Mild Detergent, Non-Abrasive Cleanser
Clean Soft Cloth / Sponge

CLEANING

1. Remove the grates from the charbroiler. Clean grates:
 - a. Use the supplied steel brush with scraper to remove food particles and residue from grate surfaces.
 - b. Grate may be washed in sink or dishwasher.
 - c. Dry the grate and apply a light coating of cooking oil.
2. Remove and clean the drip pan:
 - a. Stubborn food particles maybe removed with a plastic scouring pad.
 - b. Drip pan may be washed in a sink or dishwasher.
3. Clean broiler cabinet:
 - a. Use a plastic scouring pad to remove any remaining food particles from the cabinet.
 - b. Clean the cabinet with a soft damp cloth or sponge and mild detergent. Rinse by wiping with a soft cloth moistened with clean water. Dry with a soft cloth.
5. Reassemble broiler:
 - a. Reinstall drip pan.
 - c. Reinstall grates.

Procedure complete

CLEANING INSTRUCTIONS (continued)

PREPARATION

Turn gas shut-off valve OFF.
Allow broiler to cool before cleaning.

FREQUENCY

As Needed

TOOLS

Plastic Scouring Pad, Soft-Bristled Fiber Brush
Clean Cloth or Sponge
Mild Detergent
Cleaner Formulated for Stainless Steel
Warm Water



WARNING:
FIRE HAZARD

Shut off the gas supply valve before cleaning.

CLEANING BURNERS

If one or more individual flame openings does not light, or if the flame is intermittent or uneven, the burner may need to be cleaned.

Turn shut-off valve OFF. Remove all control knobs and remove front panel.

Note position of burner assemblies in cabinet. Remove radiants and main burners.

Examine burner assemblies. Note position of air shutters before cleaning. Clean food particles from burners with warm water, mild detergent and a bristle brush.

If necessary, reflectors may be removed from burners for cleaning by removing the retaining wire. Cleaned with a plastic scouring pad and mild detergent. Dry thoroughly before reinstalling on burners.

Rinse by wiping with a soft cloth dampened with clean water. Wipe exterior surfaces dry with a soft clean cloth. Allow burners to air dry so that interior passages are completely free of water.

Examine burners to be sure the air shutters are in their proper position. Reinstall burners with flame openings "up". The venturi / air shutter slides over the nozzle of the control valve. The pegs on the rear of the burner set in corresponding notches in the rear burner support rail.

Turn shut-off valve ON and light pilot light.

Reinstall front panel, radiants and grates and all control knobs.

Test all burners for proper operation.

Procedure is complete.

IMPORTANT: DO NOT spill or pour water into burners or controls,

DO NOT submerge broiler cabinet in water. Damage to internal components will occur. Damage to internal components from water damage is NOT covered by warranty.

TROUBLESHOOTING

SYMPTOM	POSSIBLE CAUSE	SUGGESTED REMEDY
Pilot will not light	Gas supply off	Check main / unit gas valves
	Air in lines	Turn pilot valve on. Attempt to light pilot every 15 sec.
	Pilot valve not on	Turn pilot valve on / adjust
Burners won't light	Gas supply off	Check main / unit gas valves
	Air in lines	Turn gas valve on. Attempt to light pilot every 15 sec.
	Pilot burner not lit	Turn off gas - allow unit to vent for 5 minutes. Turn gas back on and light pilot
One burner assembly won't light	Control not on	Turn control knob to ON Set to desired setting when lit
	Water in burner	Remove burner and dry thoroughly
	Damaged gas control valve, burner or other internal component	Contact Authorized ICB Service Agency for repairs
Portions of a burner won't light or have erratic flame	Burner wet or flame opening(s) clogged	Clean and dry burner
Burner not hot enough	Temperature control not set	Adjust for desired temperature
	Shutter or nozzle out of adjustment	Contact qualified technician for adjustment
	Damaged gas control valve, burner or other internal component	Contact Authorized ICB Service Agency for repairs

NOTE: There are no user serviceable components in the burner assemblies or in the control valves. In all cases of damage or malfunction, contact your Authorized ICB Service Agency for repairs.