



# COUNTERTOP MERCHANDISER

SERVING THE FOOD INDUSTRY SINCE 1951

## 35L & 50L CAPACITY DISPLAY WARMERS

Item: 41869  
Model: DW-CN-0035

Item: 41871  
Model: DW-CN-0050

DISPLAY WARM MERCHANDISE

Increase impulse **Sale**



**WARRANTY**  
PARTS AND LABOR



Authorized Dealer

# COUNTERTOP MERCHANDISER

## 35L & 50L CAPACITY DISPLAY WARMERS



### Features:

- Adjustable temperature controller
- Non-adjustable chrome plated shelf
- Stainless steel construction
- Temperature range: 30-90°C / 86-194°F



**Model DW-CN-0035**

- Single shelf unit
- Constructed with 1 front, 1 back hinged door
- Comes with 1 non-adjustable chrome plated shelf

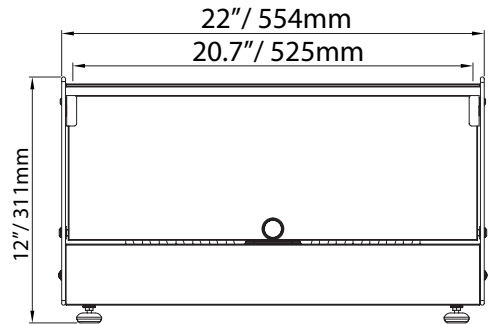
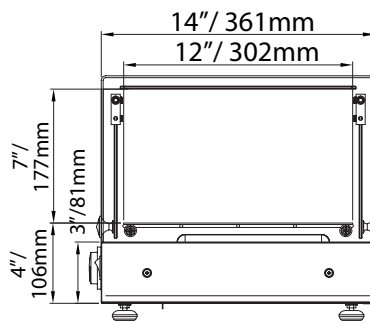

**Model DW-CN-0050**

- Dual shelf unit
- Constructed with 2 front, 2 back hinged doors
- Comes with 2 non-adjustable chrome plated shelves

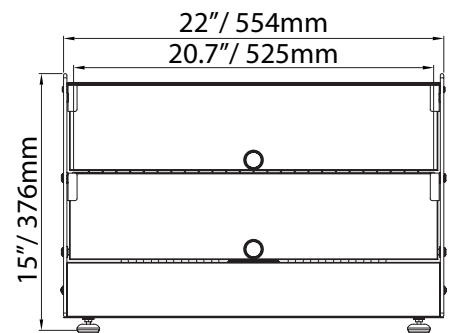
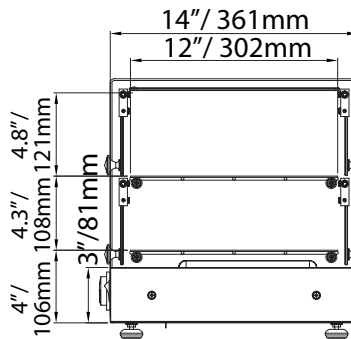

### TECHNICAL SPECIFICATIONS

|                      |  |  |
|----------------------|--|--|
| ITEM NUMBER          | 41869                                  | 41871                                    |
| MODEL                | DW-CN-0035                             | DW-CN-0050                               |
| STORAGE VOLUME       | 35L                                    | 50L                                      |
| TEMPERATURE RANGE    | 30 - 90°C/ 86-194°F                    | 30 - 90°C/ 86-194°F                      |
| POWER                | 800W                                   | 800W                                     |
| RATED CURRENT        | 6.8 A                                  | 6.8 A                                    |
| ELECTRICAL           | 110V / 60Hz                            | 110V / 60Hz                              |
| NET DIMENSIONS (DWH) | 22" x 14" x 12" / 554 x 361 x 311 mm   | 22" x 14" x 15" / 554 x 361 x 376 mm     |
| NET WEIGHT           | 25lbs. / 11.4 kg                       | 29.5 lbs./ 13.4 kg                       |
| GROSS DIMENSIONS     | 25" x 17.4" x 14" / 636 x 442 x 362 mm | 25" x 17.4" x 16.8" / 636 x 442 x 427 mm |
| GROSS WEIGHT         | 42 lbs. / 19 kg.                       | 47 lbs. / 21.3 kg.                       |

## OMCAN INC.

Telephone: 1-800-465-0234  
 Fax: (905) 607-0234  
 Email: sales@omcan.com  
 Website: www.omcan.com



Follow us to keep up to date with the latest news and offers

