



REFRIGERATION

SERVING THE FOOD INDUSTRY SINCE 1951

23 CU.FT. REACH IN REFRIGERATOR WITH 1 DOOR

Item: 50024 | Model: RE-CN-0021-HC



*High Performance and Quality
Commercial Reach In Freezer*



WARRANTY
2 YEARS PARTS & LABOR
5 YEARS ONLY ON COMPRESSOR



NEMA
5 - 15R
125 VAC / 15 AMP
RECEPTACLE



Authorized Dealer



TECHNICAL SPECIFICATIONS

ITEM NUMBER	50024
MODEL	RE-CN-0021-HC
DESCRIPTION	23 cu. ft Refrigerator
TEMPERATURE RANGE	33°F - 41°F / 0.5°C - 5°C
MAX AMBIENT TEMP RATING	90°F / 32°C
HORSEPOWER	1/5 HP
ELECTRICAL	110V / 60Hz / 1Ph
AMPS	2.6
REFRIGERANT	R290
ISOLATION MATERIAL	Cyclopentane
COOLING SYSTEM	Ventilated
NUMBER OF DOORS	1
NUMBER OF SHELVES	3
SHELF CAPACITY (KG / PC)	27 kg. / 59.5 lbs.
EXTERIOR DIMENSIONS (WDH)	29" x 32.25" x 82.5" / 736 x 818 x 2095 mm
INTERIOR DIMENSIONS (WDH)	24.4" x 27" x 60.2" / 620 x 688 x 1530 mm
PACKAGING DIMENSIONS	30 3/8" x 35" x 83 4/8" / 770 x 890 x 2120 mm
NET VOLUME	23 cu. ft. / 650 L
WEIGHT	128 kg. / 282 lbs.
PACKAGING WEIGHT	153 kg. / 337 lbs.

TECHNICAL DRAWINGS AND DIMENSIONS

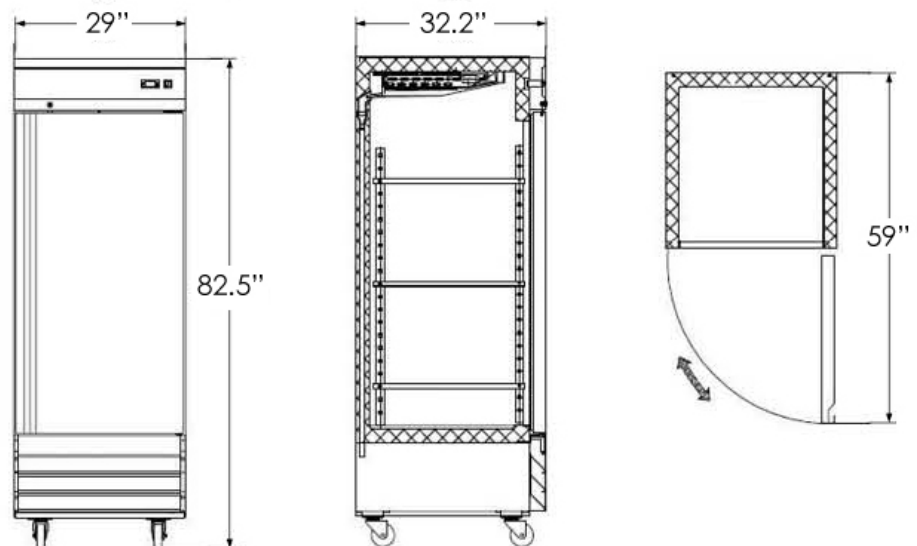

OMCAN INC.

Telephone: 1-800-465-0234
 Fax: (905) 607-0234
 E-mail: sales@omcan.com
 Website: www.omcan.com



Follow us to keep up to date with the latest news and offers



Detail Shots

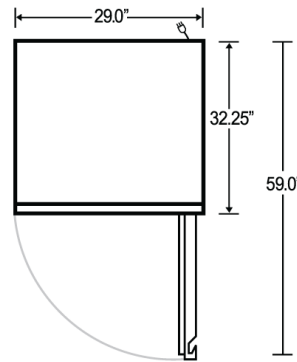
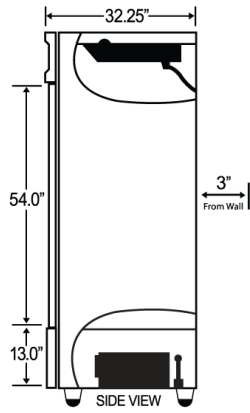
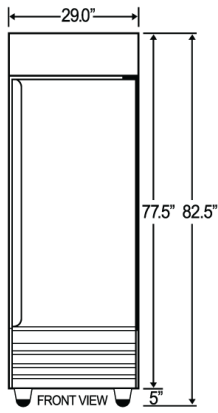
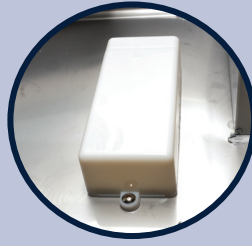

This commercial refrigerator is designed to provide high performance and efficiency. Easily control temperature with the digital temperature control and LCD display.

Features:

- 430 Stainless Steel exterior
- 304 Stainless Steel interior
- Digitally controlled temperature system
- Plastic coated shelves
- Bottom mount compressor
- Automatic defrost
- European controller and compressor
- Polyurethane insulation
- Interior lighting
- Self-closing doors
- Casters
- Lock mounted

PRODUCT SPECIFICATIONS

ITEM NUMBER	24259	COOLING SYSTEM	Ventilated
MODEL	RE-CN-0021	NUMBER OF DOORS	1
DESCRIPTION	Refrigerator	NUMBER OF SHELVES	3
TEMPERATURE RANGE	0°C ~ 10°C / 32°F ~ 50°F	SHELF CAPACITY	90 lbs./ 40.8 kg
MAX AMBIENT TEMP RATING	100.4°F	EXTERIOR DIMENSIONS (WDH)	29" x 32" x 82.5" / 74 x 81 x 209.6 cm
HORSEPOWER	0.45 HP	INTERIOR DIMENSIONS (WDH)	24.4" x 27" x 60.24" / 62 x 68.6 x 153 cm
PHASE	1	PACKAGING DIMENSIONS	31.5" x 34.6" x 85.4" / 80 x 88 x 217 cm
ELECTRICAL	110 V / 60 Hz	NET VOLUME (CU. FT.)	20.6 cu. ft.
AMPS	7.4	WEIGHT	317 lbs./ 144 kg
REFRIGERANT	R134a	PACKAGING WEIGHT	355 lbs./ 161 kg
ISOLATION MATERIAL	R141b		

OMCAN INC.

Telephone: 1-800-465-0234
 Fax: (905) 607-0234
 E-mail: sales@omcan.com
 Website: www.omcan.com



Follow us to keep up to date with the latest news and offers

