



Simply Engineered Better

501LT

Undercounter Low Temperature Dishwashing Machine



NEW!

Shown with standard top and side panels.

SPECIFIER STATEMENT

Dishwasher will be Moyer Diebel model 501LT low temperature undercounter dishwasher, complete with 1 Hp pump motor, soft start feature, all stainless steel frame and fill and drain type operation. Machine to have a minimum of 15-3/4" [400mm] opening to accommodate trays.

1 year parts and labor warranty.



Project _____

Item No. _____

Quantity _____

501LT UNDERCOUNTER

STANDARD FEATURES

- **NEW!** Industry exclusive high grade 316 stainless steel
- **NEW!** "Vari-cycle" button. Allows unlimited number of user selectable cycle times
- **NEW!** Delime cycle
- **NEW!** Auto-clean cycle
- **NEW!** Micro-computer solid-state controls
- Soft start provides gradual and quiet pump activation and prevents dish and glass breakage
- Fill and drain type operation. Rinse water always re-used as next cycle's wash water. Low 1.5 imp gal (7L) water usage per rack.
- Electric tank heater (.75 kW)
- Liquid detergent, sanitizer and rinse-aid dispensing pumps complete with prime switches
- Flexible fill and drain lines, flow regulator/line strainer and standard pumped drain for total ease of installation
- Quick 141 second cycle time. 21 racks per hour capacity
- Large 15-3/4" [400mm] door opening accommodates trays
- Rugged, counter-balanced, double skin door, for quieter operation
- Complete with two 20" x 20" [508 x 508 mm] racks (one peg and one flat)
- One year parts and labor warranty

OPTIONS & ACCESSORIES

- | | |
|---|-------------|
| <input type="checkbox"/> CST- Combination sink/table Machine on right | P/N 403561 |
| <input type="checkbox"/> CST- Combination sink/table Machine on left | P/N 403562 |
| <input type="checkbox"/> Flat bottom dishrack | P/N 101273 |
| <input type="checkbox"/> Peg dishrack | P/N 101285 |
| <input type="checkbox"/> 6" Stand | P/N 0712393 |
| <input type="checkbox"/> 17RS – 17" Stand | P/N 0708757 |

Dimensions shown in inches and [millimeters]

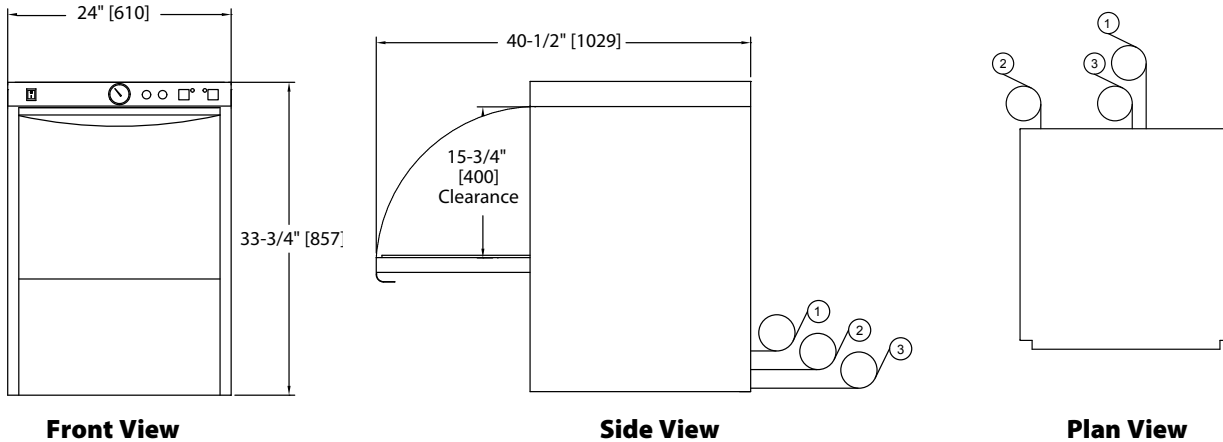

Utilities	
1 Electrical Connection	115/60/1; 12 amp draw; to be fused at 15 amp. 4ft. plug-in cord supplied.
2 Water Connection	140°F Min., 1/2" supply hot water connection 6 ft. long, 1/2" I.D. flexible fill hose with 3/4" hose connector Flow pressure: 25-95 psi (173-656 kPa)
3 Drain Connection	6 ft. long, 5/8" I.D. flexible drain hose Max. drain flow: 7 imp.gpm; 30 lpm

	Uncrated	Crated
Height*	33-3/4"	39-1/2"
Width	24"	25"
Depth	25"	25-1/2"
Ship Wt. lbs	178	198

* Front leveling feet provided.

Due to an ongoing value analysis program at Moyer Diebel, specifications in this catalog are subject to change without notice.

Moyer Diebel – Canada
2674 N. Service Rd, Jordan Station, Ontario, Canada L0R 1S0
800/263-5798 • Fax: 905/562-5422
ChampionIndustries.com/1canada • sales@moyerdiebellimited.com

SPECIFICATIONS	
Capacity	Racks per hr. 21
Motor Horsepower	Wash 1
Water Consumption	Imp.gal./liters per hr. (max. use) 31.9/145 Imp.gal./liters per rack 1.5/6.8
Temperatures °F/°C	Wash (minimum) 140°/60° Rinse (minimum) 140°/60°
Heating	Tank heat, electric (kW) .75
Time Cycle in Seconds	Wash 90 Rinse 26 Drain/fill 25 Total 141

Warning: Plumbing and electrical connections should be made by qualified personnel who will observe all the applicable plumbing, sanitary and safety codes.