



Outperform every day.™

**Project:**

**Item Number:**

**Quantity:**

## MIRAGE® DROP-IN INDUCTION WARMERS AND RETHERMALIZERS



### DESCRIPTION

Mirage® Drop-in Induction Warmers and Rethermalizers use innovative induction technology to run dry (without a water bath), improve food quality and minimize food waste; while using a fraction of the energy. They are shipped complete with an induction-ready inset and slotted hinged cover.

### WARMER PERFORMANCE CRITERIA

Mirage® Drop-in Induction Warmers are designed to hold heated prepared foods at temperatures above the HACCP “danger zone” of 140° F (60° C). The performance standard is measured using the NSF mixture preheated to 165° F (73.9° C). The unit will hold the temperature of this product above 150° F (65.6° C). The temperature will be maintained best when the food product is held using pans with covers, and the food product is stirred regularly.

### RETHERMALIZER PERFORMANCE CRITERIA

The Mirage® Drop-in Induction Rethermalizers are designed to take a container of cooked food from a chilled state (below 40.0° F [4.4° C]) through the HACCP “danger zone” of 165° F (73.9° C) in less than 90 minutes. The performance standard is measured using the NSF mixture chilled to 35° F (1.7° C). The electric unit will raise the temperature of this product above 165° F (73.9° C) in less than 90 minutes. The temperature will be maintained above 150° F (65.6° C) when the food product and pan or inset are used with a standard pan or inset cover, and the food product is stirred regularly.

### AGENCY LISTINGS



This device complies with Part 18 FCC Rules.

Cover is not NSF.

### ITEMS

- 74701DW Induction Warmer, 7Qt. (US/CAN)
- 74701D Induction Rethermalizer, 7 Qt. (US/CAN)
- 741101DW Induction Warmer, 11 Qt. (US/CAN)
- 741101D Induction Rethermalizer, 11 Qt. (US/CAN)

### FEATURES

- 3D induction coil heats food evenly and efficiently.
- Dry use. Heat is transferred directly to the induction-ready inset, which eliminates the need to monitor and refill water levels.
- Sensors monitor the temperature at three points on the inset to activate the Stir Indicator LED which notifies the operator to stir the food to maintain temperature and quality.
- Sensors reduce food waste and make clean-up easier by preventing food from burning in near-empty insets.
- Advanced solid state controls with highly visible white LEDs include: temperature control in °F and °C; four presets - broth soups, crème soups, chili, mac and cheese; rethermalize mode (800W units only); stirring indicator; and a locking function that prevents untrained operators from changing settings.
- Maximum temperature setting of 190°F.
- Includes cover — item 47488 for 7 Qt. or 47490 for 11 Qt., and inset — item 88184 for 7 Qt. or item 88204 for 11 Qt. Covers and insets are also sold separately.
- Requires use of included Vollrath induction-ready inset.
- Meets NSF4 Performance Requirements for rethermalization and hot food holding equipment.
- Bottom exit 6' (1.8 m) power cord.
- Bottom exit 58" (1.5 m) control cord.
- Includes mounting hardware.

### WARRANTY

All models shown come with Vollrath’s standard warranty against defects in materials and workmanship. For full warranty details, please refer to [www.Vollrath.com](http://www.Vollrath.com).

### ACCESSORIES

- 47491 decorative stainless steel ring for 7 Qt. induction drop-in
- 47492 decorative stainless steel ring for 11 Qt. induction drop-in

### CLEARANCE AND ENVIRONMENT REQUIREMENTS

- Failure to use Vollrath induction-ready insets may damage the unit and will void the warranty.
- All models require unrestricted intake and exhaust air ventilation for proper operation of the controls. The maximum intake temperature must not exceed 110°F (43°C). Temperatures are measured in ambient air while all appliances in the kitchen are in operation.
- Zero clearance between the sides of the drop-in and any surrounding surface.

Due to continued product improvement, please consult [www.vollrath.com](http://www.vollrath.com) for current product specifications.

Approvals	Date



Outperform every day.™

[www.vollrath.com](http://www.vollrath.com)

### The Vollrath Company, L.L.C.

1236 North 18th Street  
Sheboygan, WI 53081-3201 U.S.A.  
Main Tel: 800.624.2051 or 920.457.4851  
Main Fax: 800.752.5620 or 920.459.6573  
Customer Service: 800.628.0830  
Canada Customer Service: 800.695.8560

Technical Services  
[techservicereps@vollrathco.com](mailto:techservicereps@vollrathco.com)  
Induction Products: 800.825.6036  
Countertop Warming Products: 800.354.1970  
All Other Products: 800.628.0832

# MIRAGE® DROP-IN INDUCTION WARMERS AND RETHERMALIZERS

## DIMENSIONS (shown in inches (cm))

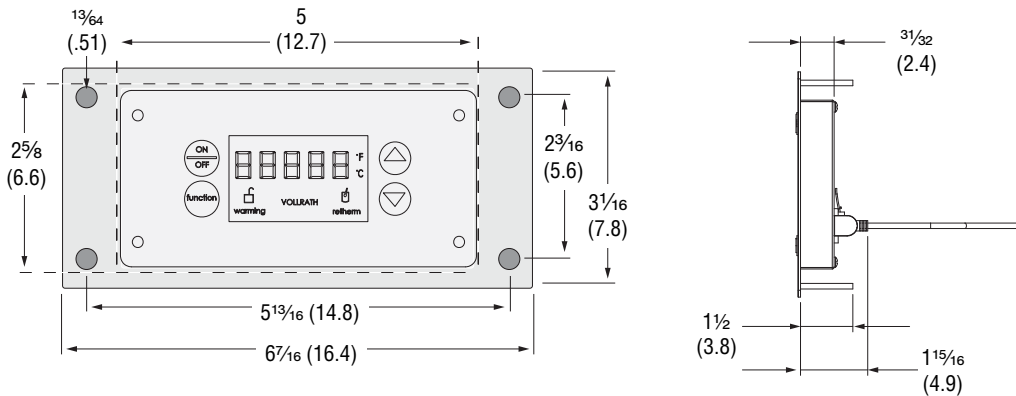
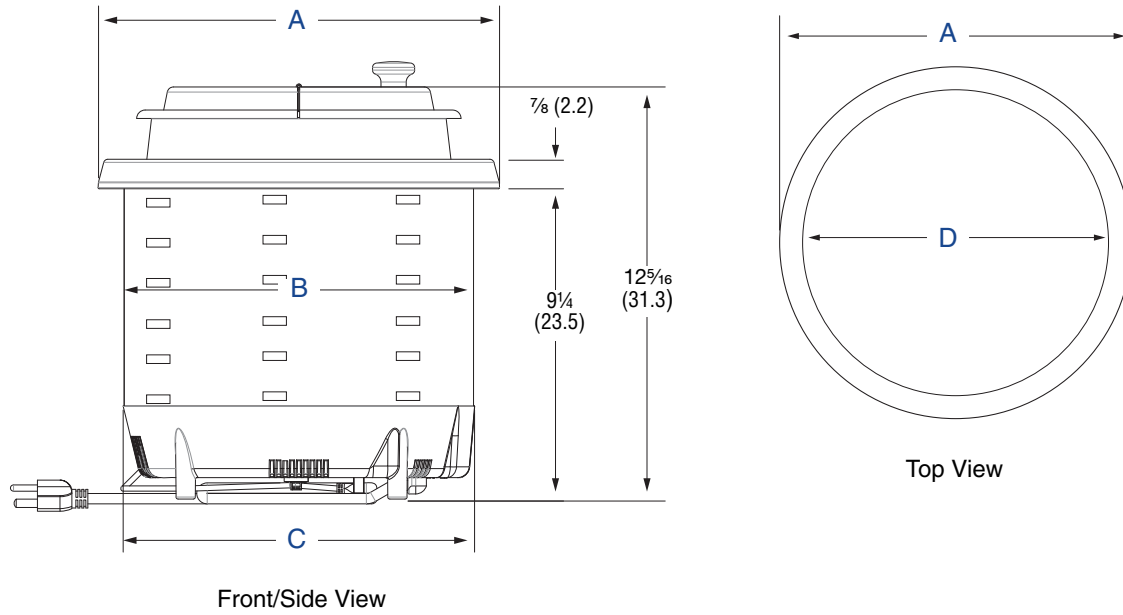

## SPECIFICATIONS

Item No.	Capacity QT (L)	Description	Dimensions				Voltage	Watts	Amps	Plug
			(A) Overall Width	(B) Drop-in Body Width	(C) Drop-in Max Width	(D) Cutout Diameter				
74701DW	7 (6.6)	Warmer	11 <sup>7</sup> / <sub>8</sub>	10 <sup>3</sup> / <sub>8</sub>	10 <sup>7</sup> / <sub>16</sub>	10 <sup>5</sup> / <sub>8</sub>	120	250W	2.1	NEMA 5-15P
74701D		Rethermalizer	(30.3)	(26.4)	(26.5)	(27)		800W	6.7	
741101DW	11 (10.4)	Warmer	13 <sup>7</sup> / <sub>8</sub>	12 <sup>3</sup> / <sub>8</sub>	12 <sup>7</sup> / <sub>16</sub>	12 <sup>5</sup> / <sub>8</sub>	120	250W	2.1	NEMA 5-15P
741101D		Rethermalizer	(35.3)	(31.4)	(31.2)	(32.1)		800W	6.7	

### Receptacle

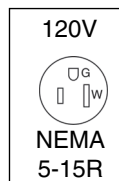

Outperform every day.™

[www.vollrath.com](http://www.vollrath.com)

### The Vollrath Company, L.L.C.

1236 North 18th Street  
 Sheboygan, WI 53081-3201 U.S.A.  
 Main Tel: 800.624.2051 or 920.457.4851  
 Main Fax: 800.752.5620 or 920.459.6573  
 Customer Service: 800.628.0830  
 Canada Customer Service: 800.695.8560

Technical Services  
[techservicereps@vollrathco.com](mailto:techservicereps@vollrathco.com)  
 Induction Products: 800.825.6036  
 Countertop Warming Products: 800.354.1970  
 All Other Products: 800.628.0832