



Our AT Express™ conveyor toasters can toast up to 300 slices of bread per hour. The small footprint of the toaster fits into tight spaces on counters to save space for other equipment.

A variable speed control for the conveyor allows the operator to dial in the perfect browning.

Top and bottom heating elements are independent so the operator can turn one on or off for one-sided toasting.

The heavy-duty stainless steel construction is built solid for high output and long life.

WARRANTY

APW Wyott AT Express toasters are backed by a 2-year parts and labor warranty, including onsite service calls within 50 miles of authorized service technicians.

CERTIFICATIONS

Certified by the following agencies:



FEATURES AT A GLANCE

- The AT Express™ toasts over 300 slices of bread per hour
- Designed to fit into tight space areas on counters
- Toasters have extended super-feeder and warming area to allow for high volume productions
- Warming area that keeps toast at the perfect temperature until you are ready to serve
- A variable speed control for the conveyor produces optimum browning
- Turn off either the top or bottom element for one-sided toasting
- Able to handle a variety of breads, bagels, or muffins
- Cool-touch exterior and top surface
- Removable conveyor and crumb trays for simple cleaning
- Removable side panel allows easy access for service
- AT Express air circulation system keeps cooling air circulating in toaster even after the power switch is turned off protecting components and exteriors from excessive residual heat
- All Stainless steel construction for durability
- 120V/60Hz or 230V/50Hz equipment with high output
- Self-dispensing bread drawer slides forward for removal of product
- High temperature bearings that do not require lubrication

EQUIPMENT DIMENSIONS

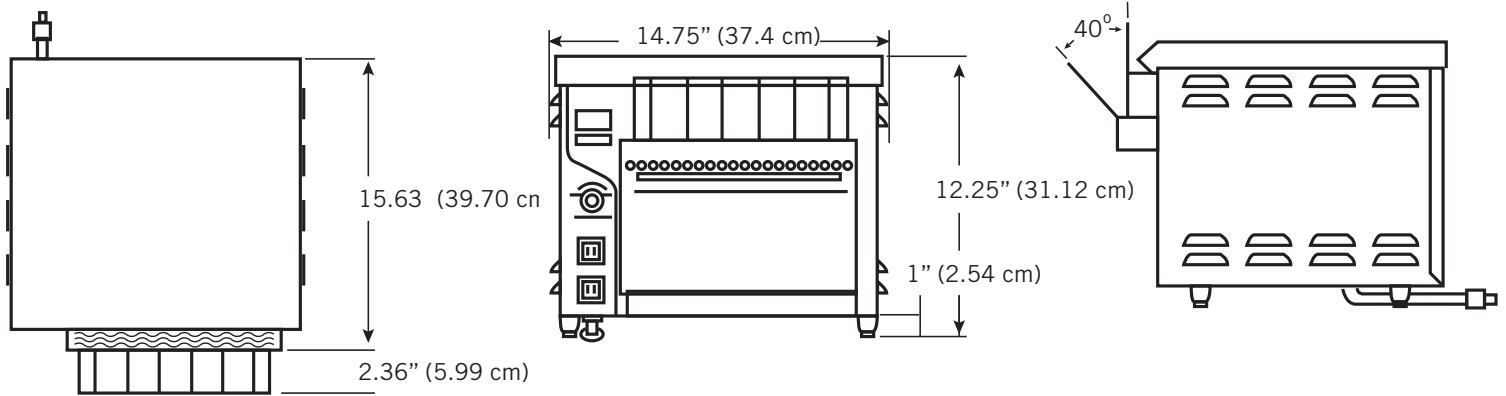

MECHANICAL SPECIFICATIONS

Model #	Volts	Watts	NEMA Plug	Amps	Hz	Overall Dimensions Width x Height* x Depth** (inches / mm)	Slices per hour	Ship Weight (lbs. / Kilos)
AT EXPRESS - 120V	120	1,300	5-15P / 5-15P	11	60	14.75" x 13.25" x 18" (375 x 337 x 457)	300	54 lbs. (24.5 kg)
AT EXPRESS - 120V	120	1,725	5-15P / 5-20P	14.4	60	14.75" x 13.25" x 18" (375 x 337 x 457)	300	54 lbs. (24.5 kg)
AT EXPRESS - 208V	208	1,725	6-15P / 6-15P	8.3	60	14.75" x 13.25" x 18" (375 x 337 x 457)	300	54 lbs. (24.5 kg)
AT EXPRESS - 240V	240	1,725	6-15P / 6-15P	7.2	60	14.75" x 13.25" x 18" (375 x 337 x 457)	300	54 lbs. (24.5 kg)
AT EXPRESS - 230V	230	1,725	6-20	7.5	50	14.75" x 13.25" x 18" (375 x 337 x 457)	300	54 lbs. (24.5 kg)

*Height includes 1" legs. **Depth includes loading tray.

ELECTRICAL INFORMATION

Each unit is equipped with a 39" (99.06 cm), three wire grounded power cord which terminates with a standard three pronged male plug.

Freight Class: 100
 FOB: Smithville, 37166

APW Wyott reserves the right to modify specifications or discontinue models without incurring obligation. Dimensions nominal.