

**CLPT-7230**  
**Compact Mega Top Prep Table**  
**Self-Contained Solid Doors**



Project \_\_\_\_\_  
AIA # \_\_\_\_\_ SIS # \_\_\_\_\_  
Item # \_\_\_\_\_ Quantity \_\_\_\_\_ C.S.I. Section 114000

**STANDARD PRODUCT FEATURES**

- Self-Contained Rear-Mounted Refrigeration System Using R-290 Refrigerant
- High Quality Stainless Steel Construction
- Anodized Aluminum Interior
- Mega Top Pan Capacity for Extra Food Storage
- LED Display Control for Accuracy and Easy Monitoring
- Stay Open Door Feature at 105°
- Capillary Tube Metering Device
- 8" Deep, 3/4" Thick, Full Length Removable Cutting Board
- NSF Approved White Polyethylene Board
- Maintains Cabinet Temperature of 32°F to 41°F
- Insulated Hood
- Tested to NSF7 Requirements
- Accommodates 6" Deep Pans
- Top Cut-Out Accommodates 1/6 Size Pans (4" deep plastic pans provided)
- Two (2) Adjustable, Heavy Duty Epoxy Coated Shelves Per Section
- Field Reversible Door(s)
- Set of Four (6) 4" H Casters, Front Three w/ Locks, Pre-Installed on Device
- Gasket-Protecting Retainer
- High-Density, Non-CFC Foamed in Place Polyurethane Insulation



Models listed to the applicable UL, CSA and NSF standards by an approved NRTL. Consult the factory or unit data plate for additional information.

**ACCESSORIES & OPTIONS (Available at Extra Cost)**

- + Additional Epoxy Coated Shelves on Pilasters
- + Set of Six (6) 6" High Legs
- + Set of Six (6) 6" High Casters
- + Set of Six (6) 2-3/4" High Casters

**AVAILABLE CONFIGURATIONS**

MODELS	HINGING
CLPT-7230-SD-LRR	Solid Doors, Left/Right/Right
CLPT-7230-SD-LLL	Solid Doors, Left/Left/Left
CLPT-7230-SD-RRR	Solid Doors, Right/Right/Right

Model	Doors	Shelves	Pans (1/6)	Dimensions L x D x H (in.)	Voltage	Amps	NEMA	Cu. Ft.
CLPT-7230	3	6	30	72.5 x 35.75 x 40*	115/60/1	2.6	5 - 15P	N/A

\*Note: 40 in. height without casters

Approved by \_\_\_\_\_ Date \_\_\_\_\_ Approved by \_\_\_\_\_ Date \_\_\_\_\_

**MODEL - CLPT-7230**

Solid Door Models - Mega Top

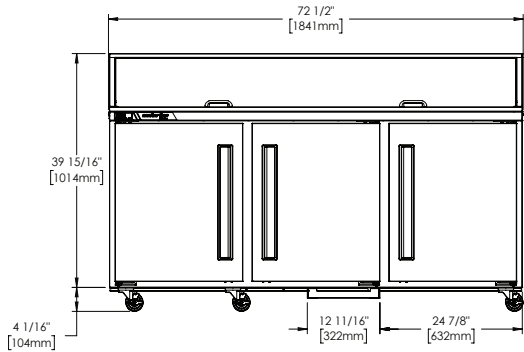

**ELEVATION**

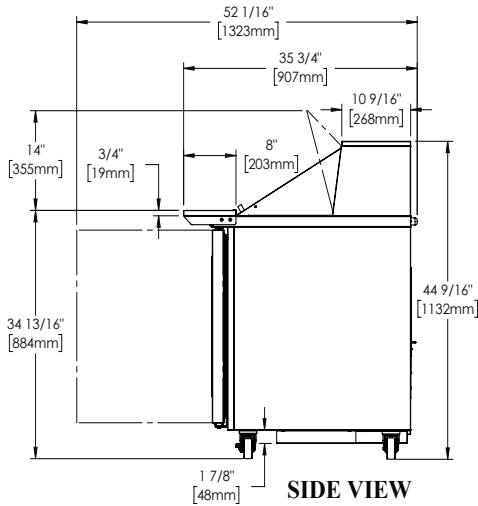

**SIDE VIEW**

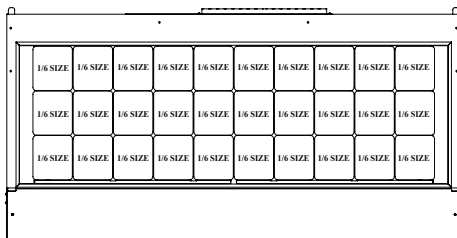

**PAN LAYOUT**

**SPECIFICATIONS**

**CONSTRUCTION, HARDWARE, INSULATION**

Cabinet exterior front, sides, and door(s) are constructed of stainless steel. Cabinet interior is constructed of anodized aluminum. 1/6 size plastic pans and a set of six (6) 4" high casters are included. Doors are equipped with a gasket protecting retainer. Both the cabinet and door(s) are insulated with an average of 2-3/8" thick high density, non-CFC, foamed in place polyurethane insulation.

**REFRIGERATION SYSTEM**

A rear mounted, self-contained, balanced refrigeration system using environmentally friendly, low GWP R-290 refrigerant is provided. It features an easy to clean rear facing condenser, capillary tube metering device, and an air-cooled hermetic compressor. A 9' cord and plug is provided. Standard operating temperature is 32°F to 41°F. Energy efficient refrigeration system maintains safe product temperatures. Condenser is located in back of unit for easy maintenance and zero clearance.

**CONTROLLER**

The easy to use electronic digital control is supplied standard. It includes a 3-Digit LED display, and a Fahrenheit or Celsius temperature scale display capability.

**INTERIOR**

Standard interior arrangements include two (2) epoxy coated wire shelves per section, mounted on pilasters. Recommended load limit per shelf should not exceed 150 lbs.

**WARRANTY**

Both a 6 Year Parts & Labor Warranty and additional 1 Year on Compressor Parts Warranty are supplied standard.

MODELS	CLPT-7230
<b>ELECTRICAL DATA</b>	
Voltage	115/60/1
Full Load Amperes	2.6
<b>REFRIGERATION DATA</b>	
Refrigerant	R-290
Refrigerant Charge oz.	3.0 (85 g)
BTU/HR <sup>1</sup>   H.P.	1800   1/5
<b>SHIPPING DATA</b>	
Depth Crated in.	35 (88.9 cm)
Height Crated in.	49 (124.5 cm)
Length Crated in.	77 (195.6 cm)
Volume Crated cu. ft.	76.4 (2164 l)
Net Weight lbs.	367 (166.6 kg)
Gross Weight lbs.	408 (185.1 kg)

NOTES:  
1. BTU/HR based on a 90°F ambient and 20°F evaporator

Equipped with one NEMA 5-15P Plug

