

CORECOMBI 62E

Electric 6-Level - Full Size Steam Generator Combi



Core-62E
shown on optional stand



SPECIFIER STATEMENT

CoreCombi model 62E features 10" touchscreen, Multi-function modes Convection, Steam, and Combi with predictive humidity control, steam generator for quality steam, programmable recipes, multi-shelf timers, automatic cleaning with water recirculation, auto descale, non-proprietary liquid chemicals, auto-reversing fan, LED lights, triple pane glass door, USB port, multi-point food probe, 3 grab-and-go wire racks. One-year limited parts and labor warranty.

Exterior Dimensions:

Combi: 33.1"H x 44.5"W x 38.6"D (without handle)
Combi: 33.1"H x 44.5"W x 41.3"D (with handle)
Combi on stand: 59.3"H x 44.5"W x 41.3"D
Stacked (62E / 62E): 71.6"H x 44.5"W x 47.4"D

Capacity:

(12) 12" x 20" hotel pans or
(6) 18" x 26" full sheet pans

MODELS

- CORE-62E-208** 6-Level full size , 208v
- CORE-62E-240** 6-Level full size , 240v
- CORE-62E-480** 6-Level full size , 480v

STANDARD FEATURES

- Multiple cooking capabilities include: bake, steam, roast, grill, air-fry, rethermalization, proof, finish, poach, stew, low temp, defrost, cook & hold and more.
- 10" touch screen.
- Multi-point food probe.
- Multi-function cooking and cleaning modes.
- Programmable recipes, Multi-Level Shelf Timers, and Multi-Product functions.
- Patented automatic humidity control based on temperature. Humidity range: low, medium & high.
- Auto cleaning wash system with water recirculation using non-proprietary liquid detergent.
- Patent-pending cavity delimiting process, in conjunction with the steam generator delimiting, provides an effective method for preventative maintenance.
- Exclusive grab-and-go racks with cutout design.
- Custom settings allow for user personalization, interactive service diagnostics, data collection and operator instructional help screens.
- Temperature: 80-575°F with visual display of set and actual temperature.
- Continuous timer: tracks up to 99:59:59 hours, minutes, and seconds. Set, remaining or count time displayed.
- Auto-reversing fan with 3 adjustable speeds.
- Flashing LED lights & audible alarm system alert user when cooking cycle ends.
- USB port to upload or download information.
- Universal spray hose kit.
- One-year limited parts and labor warranty.

ACCESSORIES - see last page

CORECOMBI 62E - Electric 6-Level - Full Size Steam Generator Combi Oven

WATER QUALITY STATEMENT

The fact that a water supply is potable is no guarantee that it is suitable for steam generation. All steam equipment is subject to contamination and failure due to chemical and mineral content found in water. A suitable Water Treatment System and regular filter replacements coupled with routine deliming is the recommended minimum. Damage as a result of poor water quality or lack of required owner/operator maintenance is the responsibility of the owner/operator.

Your water supply must be within these general guidelines:

DYNAMIC WATER PRESSURE	15-87 psi (30-60 recommended)
HARDNESS*	1 - 3 grains
SILICA	less than 13 ppm
TOTAL CHLORIDE	less than 30 ppm
pH RANGE	7-8
CHLORINE & CHLORAMINE	0 ppm
ALKALINITY	less than 20 ppm
TDS	less than 60 ppm
UN-DISSOLVED SOLIDS	less than 5 microns

* 17.1 ppm = 1 grain of hardness

Other factors affecting steam generation are iron content, amount of chlorination and dissolved gases. Water supplies vary from state to state and from locations within a state. Therefore it is necessary that the local water treatment specialist be consulted before the installation of any steam generating equipment.

USER RESPONSIBILITY

The product must be installed, cleaned and maintained as described in the Manual furnished with the product. It is the responsibility of the owner and installer to comply with local codes.

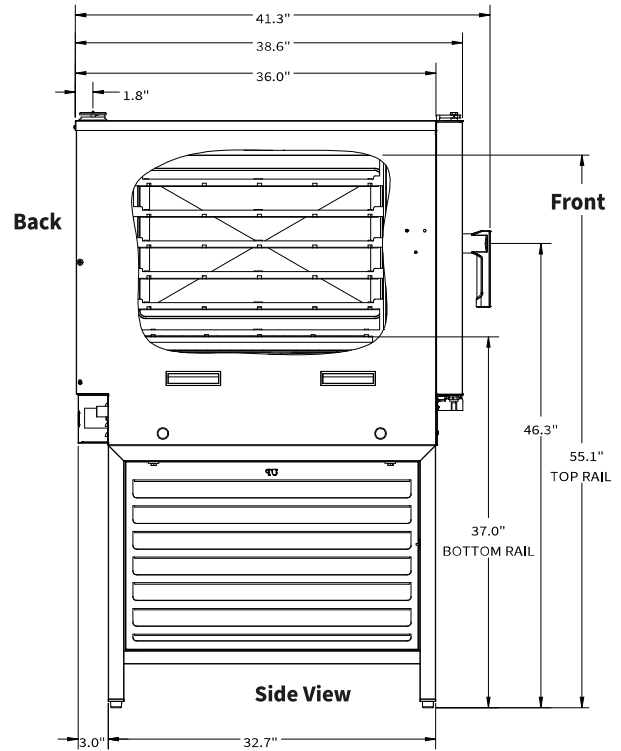
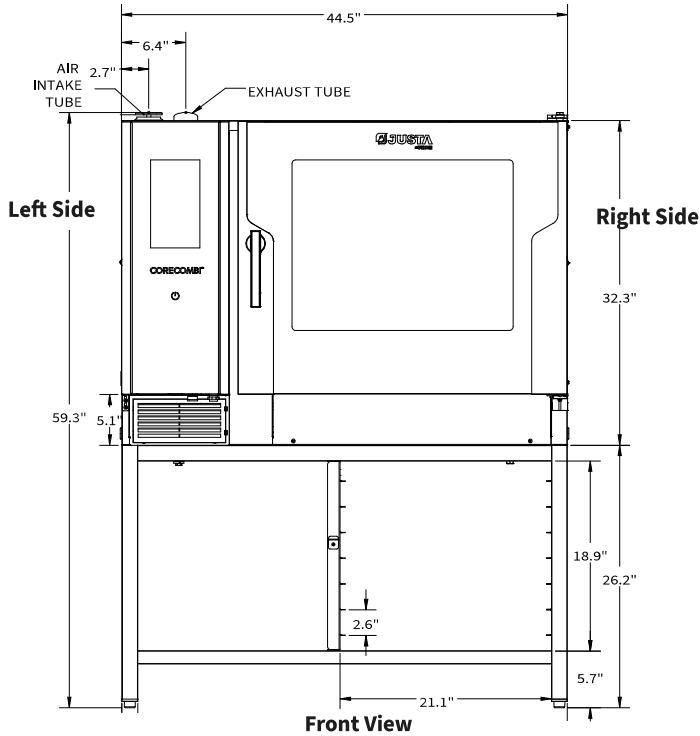

External Dimensions	Height	Width	Depth
CORE-62E	33.1"	44.5"	41.3" (w/handle)
CORE-62E on stand	59.3"	44.5"	41.3" (w/handle)
Packaged CORE-62E	40.2"	48.8"	45.9"

Weight	Machine	Shipping
CORE-62E	507 Lbs.	595 Lbs.

Clearance	Left	Back	Right
CORE-62E	2**	2.5"	2"

*External heat sources may require space or 3" optional heat shield.

Models	Volt	PH	kW	Amp
CORE-62E-208	208V	3	22kW	63A
CORE-62E-240	240V	3	22kW	55A
CORE-62E-480	480V	3	22kW	27A

Amperage values in the table are nominal. Tolerance is +5/-10%. Always refer to the NEC, state and local codes.

Service Connections
Electrical Field wire electrical connection. Ships as 208, 240, and 480V.
Water 3/4" GHT-M (male garden hose) connection on the machine. <i>Note: water is a customer supplied utility that must meet the water specs of the machine.</i>
Drain 2" diameter

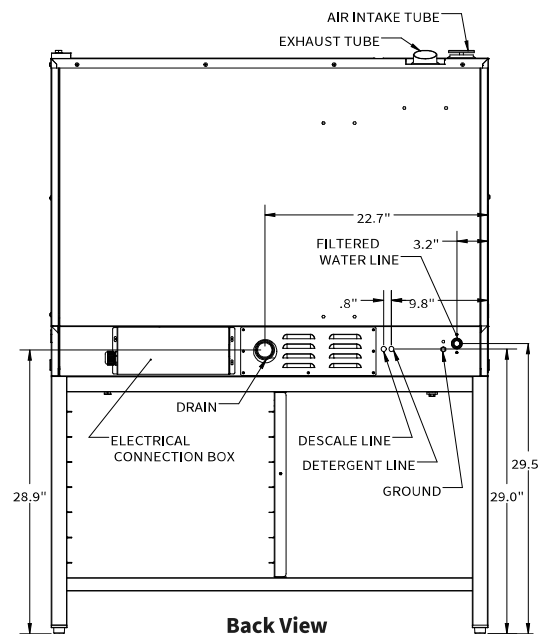

As continued product improvement is a policy of Justa by Vulcan, specifications are subject to change without notice.

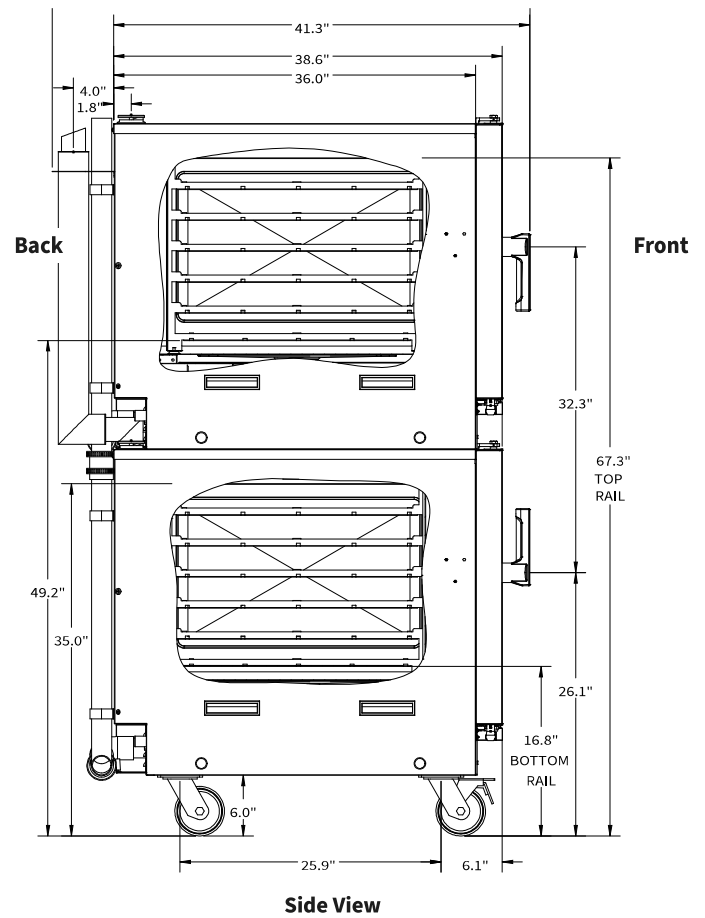
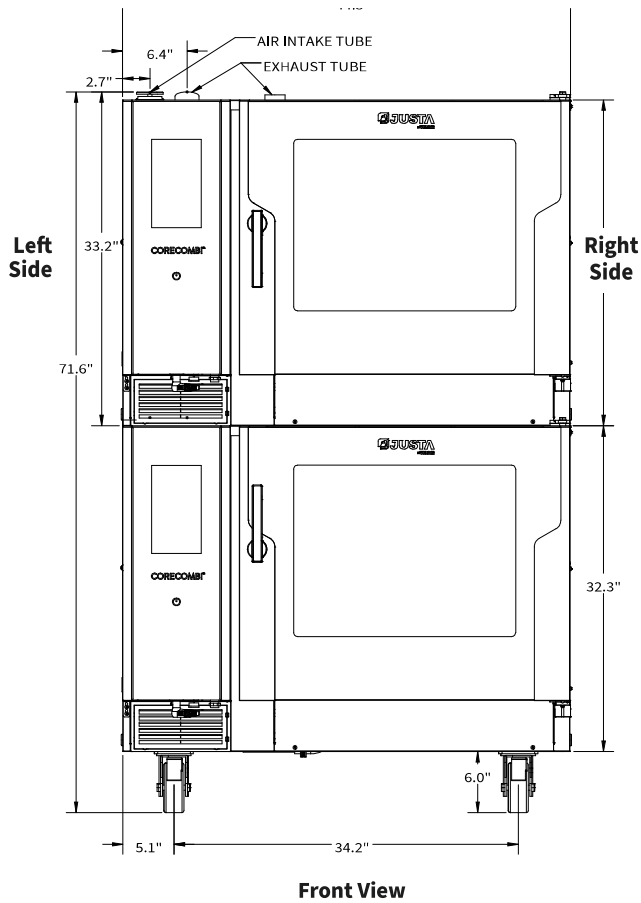

Stacked: CORE-62E/CORE62E

	Height	Width	Depth
External Dimensions	71.6"	44.5"	47.5" (w/handle)
	71.6"	44.5"	44.7" (no handle)

Clearance	Left	Back	Right
Stacked CORE-62E / CORE-62E	2"	6.5"	2"

*18" clearance recommended for service access on left side.
External heat sources from other equipment may require space or heat shield (adding 3" to total external width, eliminating left clearance need).

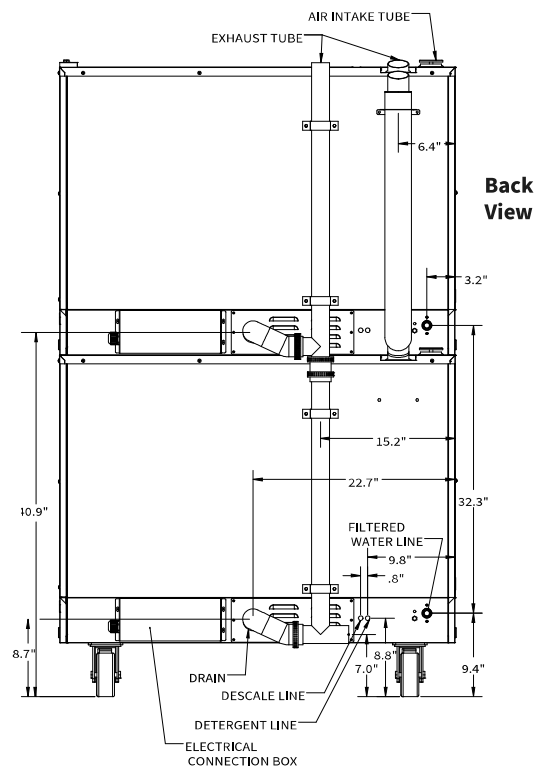

As continued product improvement is a policy of Justa by Vulcan, specifications are subject to change without notice.

ACCESSORIES

COOKING

- | | | | |
|---|---|--|-------------------------------------|
| <input type="checkbox"/> VRACK-62 | Stainless steel grab-and-go racks (5) | <input type="checkbox"/> DIAMONDGRILL | Baking and grill tray diamond shape |
| <input type="checkbox"/> PERFTRAY1.1 | Perforated baking tray 12"x20" | <input type="checkbox"/> ROAST-BAKETRAY | Roasting and baking tray |
| <input type="checkbox"/> PERFTRAY2.1 | Perforated baking tray 20"x24" | <input type="checkbox"/> CHICKRACK6 | Stainless steel chicken rack - 6 |
| <input type="checkbox"/> EGGTRAY | Eggs tray 8 holes | <input type="checkbox"/> CHICKRACK8 | Stainless steel chicken rack - 8 |
| <input type="checkbox"/> ENAMEL40 | Tray granite enameled depth 40mm | <input type="checkbox"/> RIBRACK | Ribs rack |
| <input type="checkbox"/> ENAMEL60 | Tray granite enameled depth 60mm | <input type="checkbox"/> 1220-GRILLOP | Grilling grid (open type) |
| <input type="checkbox"/> PIZZATRAY | Pizza and baking tray | <input type="checkbox"/> 1220-BASKET | Stainless steel fry basket 12"x20" |
| <input type="checkbox"/> GRILL-PIZZATRAY | Cross grill & pizza DURAGUARZ coated reversible | <input type="checkbox"/> FRYBASKET | Frying baskets coated with DURAPEK |

STANDS, STACKING KITS, CASTERS AND FEET

- | | |
|---|-------------------------------------|
| <input type="checkbox"/> CORE-STAND2 | Stainless steel stand with shelving |
| <input type="checkbox"/> CORE-CAST | Stand caster kit |
| <input type="checkbox"/> CORE-STACK62E | Stacking kit |
| <input type="checkbox"/> CORE-STACKCAST3 | 3" low profile stacking casters |
| <input type="checkbox"/> CORE-DCSTACK | Drain connection kit stacking |
| <input type="checkbox"/> CORE-DCSTAND | Drain connection kit stand |
| <input type="checkbox"/> CORE-FEET | Adjustable feet kit |

WATER FILTRATION

- | | |
|--|---|
| <input type="checkbox"/> CB15K-SYSTEM | Hollow Carbon Filter System 15,000 gal. (carbon only treatment) |
| <input type="checkbox"/> CB30K-SYSTEM | Hollow Carbon Filter System 30,000 gal. (carbon only treatment) |
| <input type="checkbox"/> SMF600-SYSTEM | ScaleBlocker® (carbon with scale inhibitor) water filtration system |
| <input type="checkbox"/> SMF620-SYSTEM | ScaleBlocker® (carbon with scale inhibitor) water filtration system |
| <input type="checkbox"/> WS40-NOINSTALL | Water Softening (Carbon CBK System required) 40-lb capacity (hard water treatment) |
| <input type="checkbox"/> WS80-NOINSTALL | Water Softening (Carbon CBK System required) 80-lb capacity (hard water treatment) |
| <input type="checkbox"/> HOSEWTR3/4BBV | Flex stainless steel water connection 72", 3/4" GHT-F (female garden hose) on both ends |

CLEANER

- | | |
|---------------------------------------|---|
| <input type="checkbox"/> VDL-1 | Vulcan detergent liquid, 2 per package, 2.5 gal each, sold per case |
| <input type="checkbox"/> VRL-1 | Vulcan rinse (descale) liquid, 2 per package, 2.5 gal each, sold per case |

MISC

- | | |
|---|--|
| <input type="checkbox"/> CORE-HEAT62 | Heat shield (for single or stacked machines) |
|---|--|