

PROJECT:

QTY:

ITEM No.

# CTR-CVR-XX48FA

## CLASSIC V REFRIGERATED DISPLAY CASE(FORCED AIR)

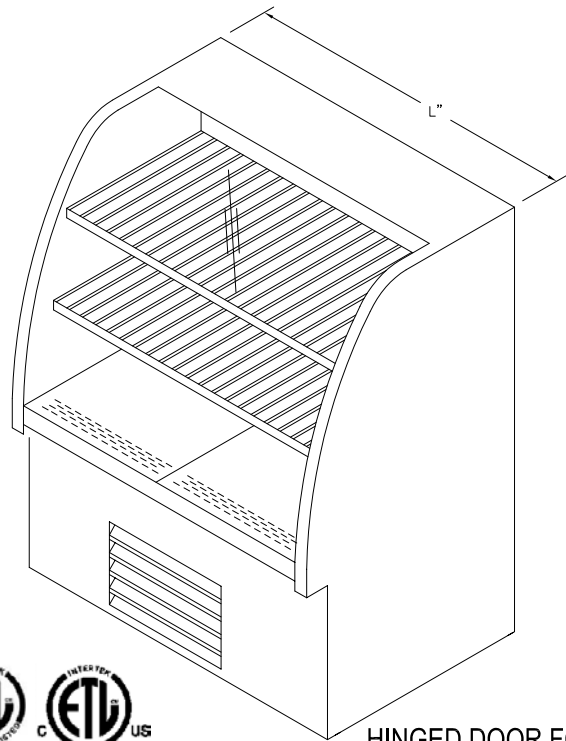
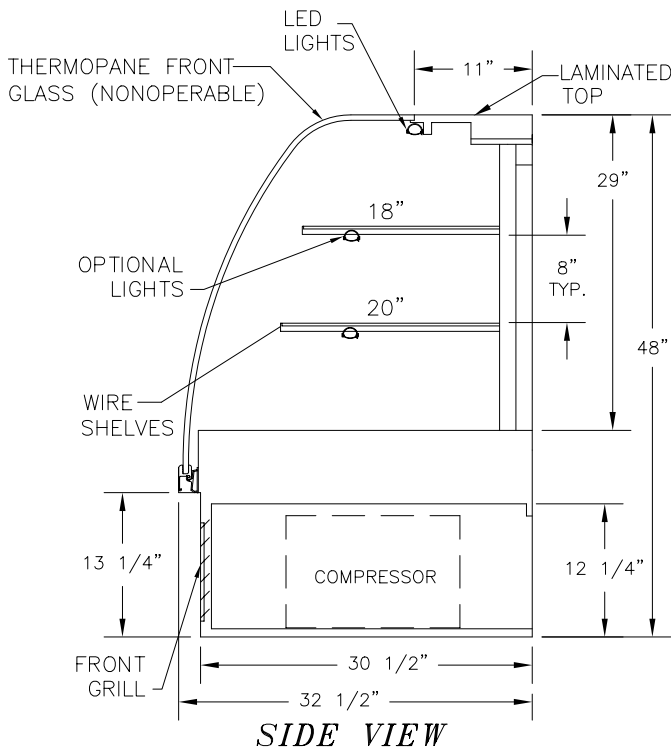

### SPECIFICATIONS

DIMENSIONS	CVR-2448FA	CVR-3648FA	CVR-4848FA	CVR-6048FA	CVR-7248FA	MODEL No.
Length (in)	24"	36"	48"	60"	72"	L
Depth (in)	32.50"	32.50"	32.50"	32.50"	32.50"	D
Height (in)	48"	48"	48"	48"	48"	H
ELECTRICAL						
Voltage	120	120	120	120	120	120
Amperes (Compressor and Light)	9.3	9.6	9.6	9.9	12.8	Amps.
Amperes (Elect. Cond. Pan needs separate circuit)	Amps.	Amps.	Amps.	Amps.	Amps.	Amps.
Power Cord	8 ft.	8 ft.	8 ft.	8 ft.	8 ft.	8 ft.

### NOTES

All Specifications subject to change without notice.

This Design is the property of QBD Modular Systems Inc. No copies or reproductions are permitted without the written permission of QBD Modular Systems Inc.

\*\* All units are designed to operate under normal store conditions of 24°C (75°F) with 50% relative humidity, and maintain the temperature between 35°F to 40°F.

\*\*Condensation on glass may occur in Hot/Humid conditions.QBD is not responsible for any consequential damages as a result.

\*\*QBD WARRANTY DOES NOT INCLUDE PRODUCT LOSS OR CONSEQUENTIAL DAMAGES HOWEVER CAUSED.



Manufacturers of food service displays



**QBD MODULAR SYSTEMS INC.**

31 BRAMSTEELE ROAD, BRAMPTON, ONTARIO, CANADA L6W 3K6

[WWW.QBD.COM](http://WWW.QBD.COM)

1-800-663-3005

TEL: (905) 459-0709

FAX: (905) 459-1478

[info@qbd.com](mailto:info@qbd.com)

DR. BY: **Dave**

DATE: **12/ 13/ 12**

FILE: **CVRXX48FA**