



REVERSIBLE DOUGH SHEETER



Reversible Dough Sheeter, Bench Model, 20 Speeds, 19 11/16" Stainless Steel Rollers, Adjustable Roller Gap (1-40mm), Enamel Coating, 1 HP, CE & ETL Listed



PROJECT _____

ITEM NO. _____

NOTES _____

MODEL NUMBER: **LSA516 , LSA520**



FEATURES

- Bench Model
- Removable Arms
- 20 Adjustable Speeds
- Fold Up Belts for Easy Storage
- Synchronized Belt System
- Adjustable Thickness from 1/32" - 1 1/2" (1 - 40 mm)
- Control Belt by Either the Dual Hand Controls
- 22 lb. Dough Capacity
- Emergency Stop
- 30 lb. Dough Capacity
- Thermal Overload Protection on Motor
- Easy to Remove & Adjust Scrapers
- Protective Guards with Motor Shut-Off Feature

CONSTRUCTION

- Polyurethane Belts
- Stainless Steel Rollers
- Stainless Steel Catch Pans (each side)
- Plastic Food Grade Flour Reservoir (above rollers)
- [2] Polyurethane Roll Pins

OPTIONS & ACCESSORIES

- Stainless Steel Construction (Suffix I)
- Heavy Duty Stand with Casters (LSB516T)

CLEARANCES

- 6" (152mm) - All Sides (do not place anything below belt)

WARRANTY

- One Year Labor & Two Year Parts



Model	Crated Weight	Overall Dimensions			Conveyor Dimensions		Electrical System		NEMA
		W	D	H	D	W	Volts	Amps	
LSA516	386 (174)	74.80" (1900)	37.79" (960)	32.48" (825)	18.89" (480)	63" (800 x 2)	120	8.3	5-15P
LSA520	394 (179)	90.55" (2300)	37.79" (960)	32.48" (825)	18.89" (480)	78.74" (1000 x 2)	120	8.3	5-15P





PROJECT _____

ITEM NO. _____

NOTES _____

MODEL NUMBER: **LSA 516 , LSA 520**

DRAWINGS

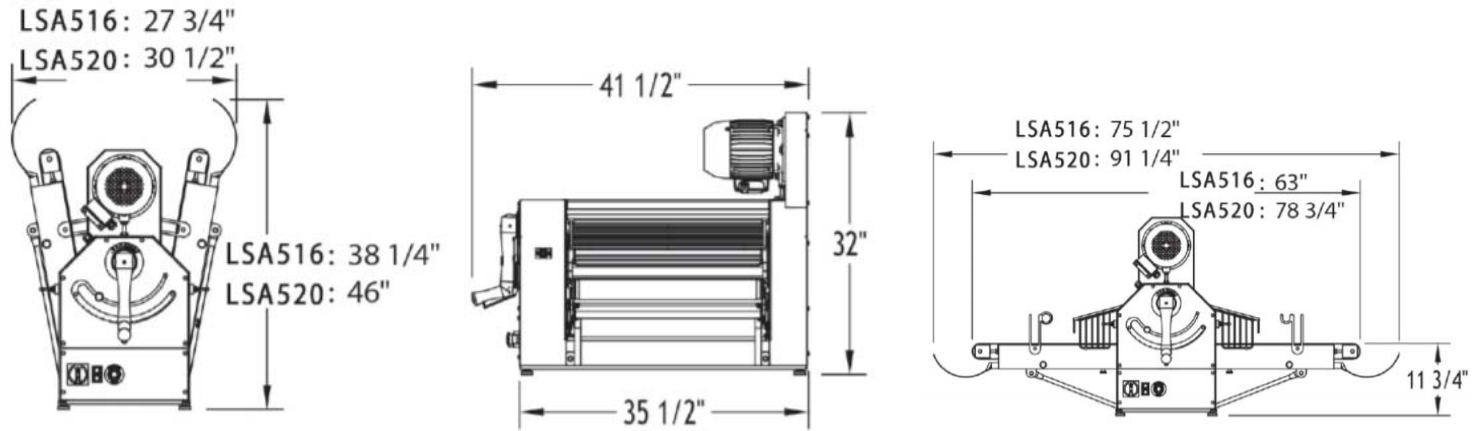

NEMA 5-15 PLUG

