



# COOKING EQUIPMENT

SERVING THE FOOD INDUSTRY SINCE 1951

## ENTRY MAX SERIES PIZZA OVENS WITH SINGLE CHAMBER AND DOUBLE CHAMBER

Item #: 40635/ 40636

Model #: PE-IT-0019-S/ PE- IT-0038-D



The Entry Max pizza ovens are practical which are ideal for pizzas, bread and kitchen products.



**WARRANTY**  
PARTS AND LABOR



Authorized Dealer

# COOKING EQUIPMENT

ENTRY MAX SERIES PIZZA OVEN WITH SINGLE CHAMBER



## Features:

- Stainless steel front, two mechanical thermostats per chamber, heat resistant, light, main switch for each chamber, stainless steel door with glass and handle (Each chamber is independent)
- Up to 2 single-chamber oven can be placed on top of each other without the need for an exhaustor connection
- Insulation is evaporated fiberglass
- Left-sided handles
- Upon request the machines can be produced in a "full refractory stone" version and for single-phase operation.
- \* *Special Order are available for the following upon request: stands, casters, hoods, vents and suction motor*

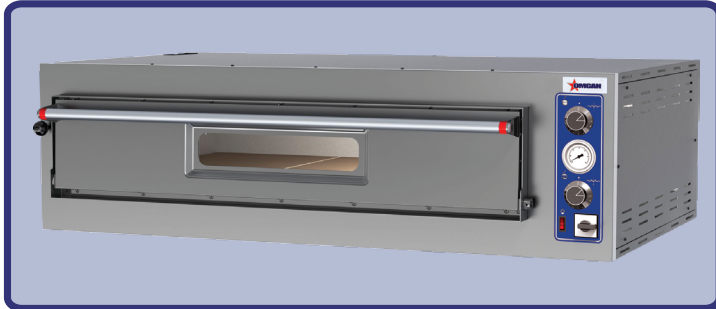

## 5.6 kW Entry Max Series Pizza Oven with Single Chamber

ITEM NUMBER	40635
MODEL	PE-IT-0019-S
MAXIMUM TEMPERATURE	842° F / 450° C
ELECTRICAL POWER	220V / 60 /3
CHAMBER DIMENSIONS (LxDxH)	27.6" x 27.6" x 5.9" / 700 x 700 x 150 mm
FULL REFRACTORY STONE DIMENSIONS	26.4" x 27" x 5.31" / 670 x 685 x 135 mm
EXTERNAL DIMENSIONS (LxDxH)	39" x 36" x 15" / 990 x 920 x 380 mm
PACKAGING DIMENSIONS (LxDxH)	40.2" x 39" x 20.9" / 1020 x 990 x 530 mm
NET WEIGHT	74 kg / 163 lbs.
GROSS WEIGHT	77 kg. / 170 lbs.

## Related Accessories - sold separately

ITEM NUMBER	DESCRIPTION
41600	Stainless steel stand
41607	Stainless steel hood
40645	Wheels for all pizza oven stands

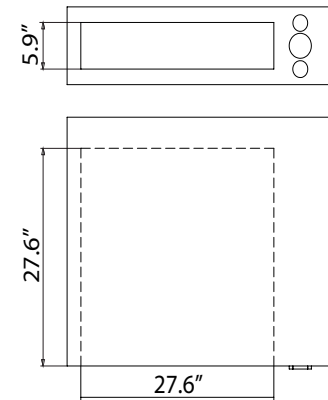
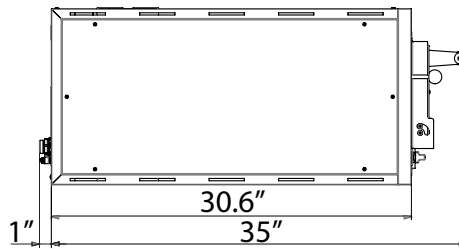
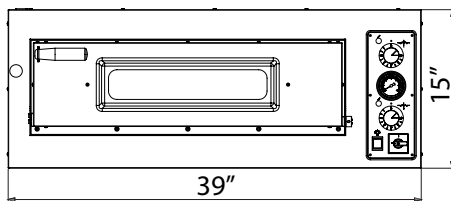

 max 4 x 12"	 max 4 x 13"	 max 1 x 18"	 max 1 x (24" x 16")
-----------------	-----------------	-----------------	-------------------------

## OMCAN INC.

Telephone: 1-800-465-0234  
 Fax: (905) 607-0234  
 E-mail: sales@omcan.com  
 Website: www.omcan.com



Follow us to keep up to date with the latest news and offers



# COOKING EQUIPMENT

ENTRY MAX SERIES PIZZA OVEN WITH DOUBLE CHAMBER



## Features:

- Stainless steel front, two mechanical thermostats per chamber, heat resistant, light, main switch for each chamber, stainless steel door with glass and handle (Each chamber is independent)
  - Up to 2 single-chamber oven can be placed on top of each other without the need for an exhauster connection
  - Insulation is evaporated fiberglass
  - Left-sided handles
  - Upon request the machines can be produced in a "full refractory stone" version and for single-phase operation.
- \* Special Order are available for the following upon request: stands, casters, hoods, vents and suction motor*



## 11.2 kW Entry Max Series Pizza Oven with Double Chamber

ITEM NUMBER	40636
MODEL	PE-IT-0038-D
MAXIMUM TEMPERATURE	842° F / 450° C
ELECTRICAL	220V / 60 / 3
POWER	11.2 kW
CHAMBER DIMENSIONS (LxDxH)	27.6" x 27.6" x 5.9" (x2) / 700 x 700 x 150 mm (x2)
FULL REFRACTORY STONE DIMENSIONS	26.4" x 27" X 5.31" / 670 x 685 x 135 mm
EXTERNAL DIMENSIONS (LxDxH)	39" x 36" x 26.7" / 990 x 920 x 680 mm
PACKAGING DIMENSIONS (LxDxH)	40.2" x 39" x 32.3" / 1020 x 990 x 820 mm
WEIGHT	149 kg / 328.5 lbs.
GROSS WEIGHT	165 kg / 363 lbs.

## Related Accessories - sold separately

ITEM NUMBER	DESCRIPTION
41422	Stainless steel stand
41607	Stainless steel hood
40645	Wheels for all pizza oven stands

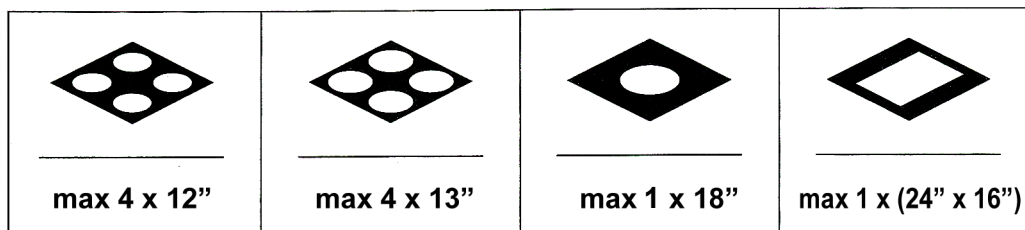
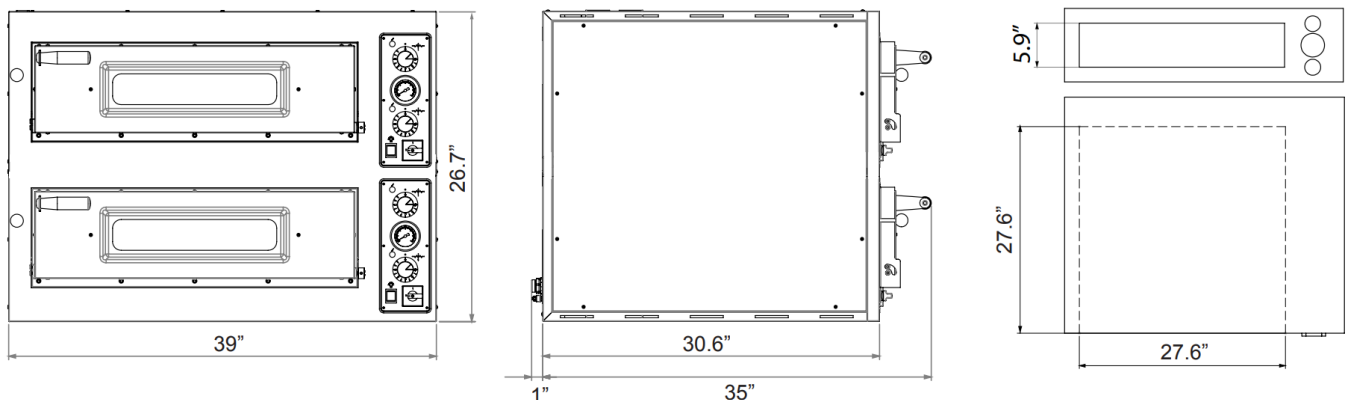

## OMCAN INC.

Telephone: 1-800-465-0234  
 Fax: (905) 607-0234  
 E-mail: sales@omcan.com  
 Website: www.omcan.com



Follow us to keep up to date with the latest news and offers

