



FOOD EQUIPMENT

SERVING THE FOOD INDUSTRY SINCE 1951

19L SALAD SPINNER

Item: 43454

9.5L SALAD SPINNER

Item: 43637



DRY LETTUCE THE EASY WAY

Dry your salad effortlessly in no time with Omcan's salad spinner. Features a sealed rotating system to ensure food safety and meets the FDA's hygiene standards. They both come with a non-slip handle that can be rotated in different directions.



Authorized Dealer

FOOD EQUIPMENT

19L - 9.5L SALAD SPINNER



Brake System:

Omcan's 19L, and 9.5L salad spinners come with a big advantage amongst other competitors with a built in brake system. While most salad spinners only come with a handle to stop which can damage the gear inside. Omcan's salad spinners can easily utilize the built in brake to slow the mechanism and prolong the longevity of your Omcan salad spinner.



Heavy Duty Construction:

These units require no assembly and accomodates a large capacity for vegetables. Which makes it an essential for any restaurants.

ITEM NUMBER	43454	43637
DESCRIPTION	19 Litre - 5 Gallons	9.5 Litre - 2.5 Gallons
COLOUR	Orange	Orange
PACKAGING DIMENSIONS	45x45x51cm / 17x17x20 Inches	39x39x42cm / 15.3x15.3x16.5 Inches
NET WEIGHT	4.25 kgs - 9.37 lbs	3.27 kgs - 7.20 lbs
GROSS WEIGHT	5.27 kgs - 11.62 lbs	3.96 - 8.73 lbs

43454 - 19 LITRE / 5 GALLONS

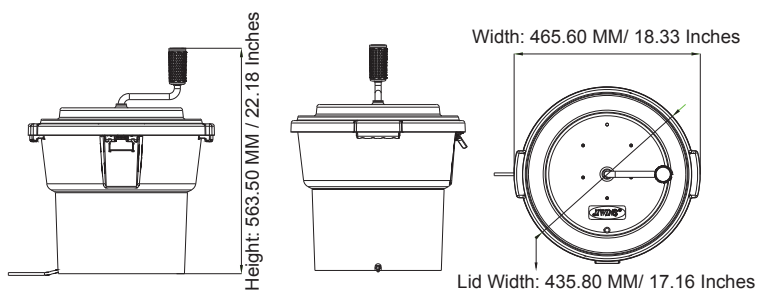

43637 - 9.5 LITRE / 2.5 GALLONS

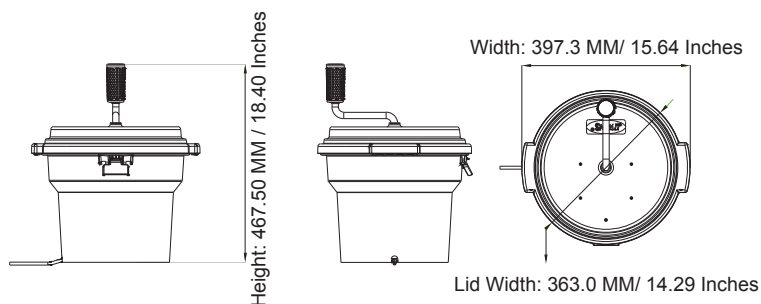

OMCAN INC.

Telephone: 1-800-465-0234
 Fax: (905) 607-0234
 Email: sales@omcan.com
 Website: www.omcan.com



Follow us to keep up to date with the latest news and offers

