



REFRIGERATION

SERVING THE FOOD INDUSTRY SINCE 1951

48-INCHES REFRIGERATED DISPLAY CASE WITH CURVED GLASS

Item: 44502

Model: RS-CN-0371



***ATTRACTIVELY DISPLAY FOOD
MERCHANDISE AND INCREASE
IMPULSE SALE***

Omcans Curved Glass Floor Refrigerated Display Case provides an economical solution for displaying your products. Features an exterior tempered glass finish and interior LED lighting, this refrigerated showcase also has an automatic defrost system and fan cooling system. Easy to use and clean. Ideal for deli shops, cafes, and sandwich shops.



WARRANTY
PARTS AND LABOR



Authorized Dealer

REFRIGERATION

48-INCHES REFRIGERATED DISPLAY CASE WITH CURVED GLASS



FEATURES

- Brilliant internal LED lighting each shelf and bottom
- 3 adjustable glass shelves
- Digital temperature control and display
- Double tempered glass
- 4 castors with 2 brakes
- Ventilated cooling system
- Automatic defrost

TECHNICAL SPECIFICATIONS

ITEM NUMBER	44502
MODEL	RS-CN-0371
CAPACITY	420 L / 14.83 cu.ft
TEMPERATURE	0-12°C / 32-54°F
POWER	540 W
COMPRESSOR POWER	3/8 HP / 510 W
LAMP POWER	41 W
REFRIGERANT	R290
BLOWING GAS	FRONT
TYPE OF CLIMATE	4
ELECTRICAL	110V/60HZ/1PH
RATED CURRENT	6.3 Amps
NET WEIGHT	390.2 lbs. / 177 Kgs
GROSS WEIGHT	467.4 lbs. / 200 Kgs
SHELF DIMENSIONS	(1) 48.6" x 10" / 1235 x 261 mm (1) 48.6" x 14.4" / 1235 x 311 mm (1) 48.6" x 14.6" / 1235 x 371 mm
INNER DIMENSIONS	45" x 23" x 32.7" / 1145 x 585 x 830 mm
NET DIMENSIONS	48" x 26.8" x 56" / 1225 x 680 x 1420 mm
GROSS DIMENSIONS	53" x 32" x 65" / 1345 x 785 x 1655 mm

TECHNICAL DRAWINGS AND DIMENSIONS

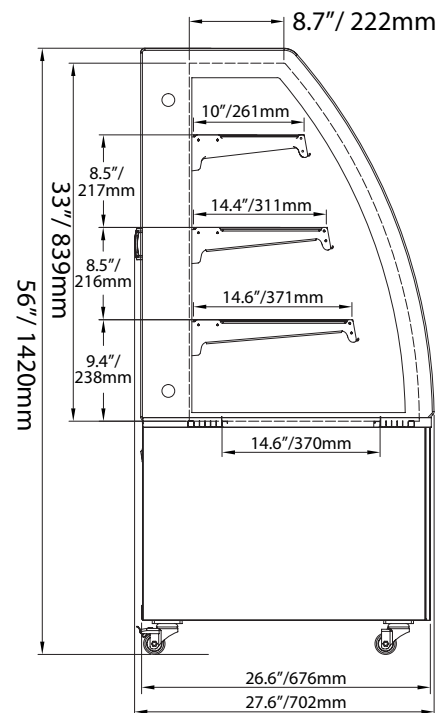
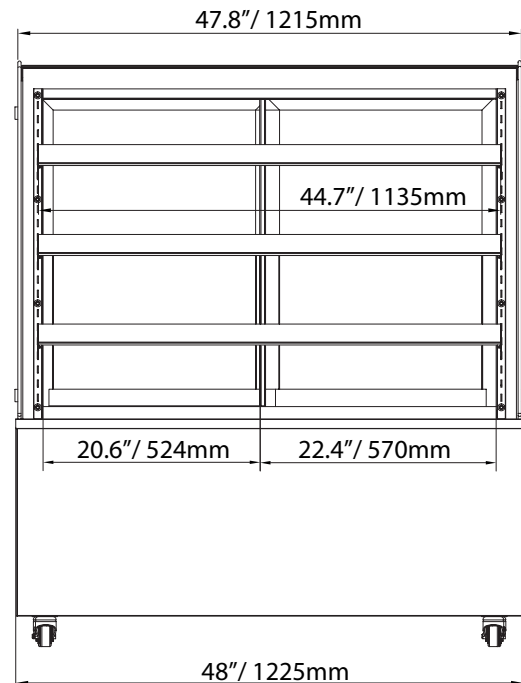

NEMA
5 - 15
125 VAC / 15 AMP
RECEPTACLE



OMCAN INC.

Telephone: 1-800-465-0234

Fax: (905) 607-0234

Email: sales@omcan.com

Website: www.omcan.com



Follow us to keep up to date with the latest news and offers



2019.E.O.E