

Vector® H Series Multi-Cook Oven

ALTO-SHAAM

UL-Listed

Providing an unmatched volume and variety of food, Vector H Series countertop models are specifically designed for foodservice operations where space is at a premium but food demand is high.

Featuring up to four independent oven chambers, operators can control the temperature, fan speed and cook time in each individual chamber for maximum flexibility – simultaneously cooking a variety of menu items with no flavor transfer.

Exclusive Structured Air Technology® delivers focused heat for faster, more even cooking and consistent, high-quality results.

Reduce labor by eliminating extra steps in food production and the need to watch and rotate pans.

Place anywhere with a small, 21" [533mm] footprint and ventless, waterless operation.

An advanced control – designed intentionally simple – features an intuitive, user-friendly interface and programmable recipes to ensure consistency with each cook.

ChefLinc™, cloud-based remote oven management software, streamlines processes and maximizes profits with data-driven insights (deluxe control only).

ISO 9001:2015-certified



VMC-H4 VMC-H3 VMC-H2

Standard Features

- Programmable, touchscreen control
- Easy recipe upload/download via USB port
- UL-listed ventless catalytic converter
- Double-pane glass door
- One [1] wire stainless steel rack and two [2] jet plates per cooking chamber
- 4" [102mm] adjustable legs
- Cord and plug on 208-240V models [except Canada]



CAPACITY

- 2** VMC-H2: 2 shelf, 2 half-size sheet pans—18" x 13" x 1" [2 GN 2/3 pans—354mm x 325mm x 25mm]
- 3** VMC-H3: 3 shelf, 3 half-size sheet pans—18" x 13" x 1" [3 GN 2/3 pans—354mm x 325mm x 25mm]
- 4** VMC-H4: 4 shelf, 4 half-size sheet pans—18" x 13" x 1" [4 GN 2/3 pans—354mm x 325mm x 25mm]
- 2** VMC-H2H: 2 shelf, 2 full-size hotel pans—20-3/4" x 12-3/4" x 4" [2 GN 1/1 pans - 530mm x 325mm x 65mm] or 2 half-size sheet pans—18" x 13" x 1" [2 GN 2/3 pans—354mm x 325mm x 25mm]
- 3** VMC-H3H: 3 shelf, 3 full-size hotel pans—20-3/4" x 12-3/4" x 4" [3 GN 1/1 pans—530mm x 325mm x 65mm] or 3 half-size sheet pans—18" x 13" x 1" [3 GN 2/3 pans—354mm x 325mm x 25mm]
- 4** VMC-H4H: 4 shelf, 4 full-size hotel pans—20-3/4" x 12-3/4" x 4" [4 GN 1/1 pans—530mm x 325mm x 65mm] or 4 half-size sheet pans—18" x 13" x 1" [4 GN 2/3 pans—354mm x 325mm x 25mm]

Configurations (select one)

Models

These models accommodate a half-size sheet pan

- VMC-H2
- VMC-H3
- VMC-H4

These models accommodate a full-size hotel pan

- VMC-H2H
- VMC-H3H
- VMC-H4H

Control

- Deluxe
- Simple

Kit

- Ethernet Cable [5030518] for Deluxe only

Door swing

- Right hinged
- Left hinged

Electrical

VMC-H2/H2H

- 208-240V, 1PH, with cord and plug
- 208-240V, 1PH, no cord, no plug [Canada]
- 220-240V, 1PH, no cord, no plug
- 380-415V, 3PH, no cord, no plug

VMC-H3/H3H

- 208-240V, 1PH, with cord and plug
- 208-240V, 1PH, no cord, no plug [Canada]
- 208-240V, 3PH, with cord and plug
- 208-240V, 3PH, no cord, no plug [Canada]
- 220-240V, 1PH, no cord, no plug
- 380-415V, 3PH, no cord, no plug

VMC-H4/H4H

- 208-240V, 3PH, with cord and plug
- 208-240V, 3PH, no cord, no plug [Canada]
- 380-415V, 3PH, no cord, no plug

Accessories

- See accessories brochure for all available accessories

Casters

- 3" [76mm] casters, set of four [4] [5027946]

Cookware

- Jet plate assembly, half-size sheet pan [5025235]
- Jet plate assembly, hotel pan [5025236]
- Wire shelf, half-size sheet pan [SH-37662]
- Wire shelf, hotel pan [SH-39077]

Cleaning

- Alto-Shaam® non-caustic cleaner, one [1] bottle [CE-46828]
- Alto-Shaam® non-caustic cleaner, case of six [6] bottles [CE-46829]

Grease filters

- Internal chamber filters—order one [1] kit per chamber [5027119]



ANSI/NFPA 4



IP X4



COA #5879

Vector® H Series Multi-Cook Oven

Specification

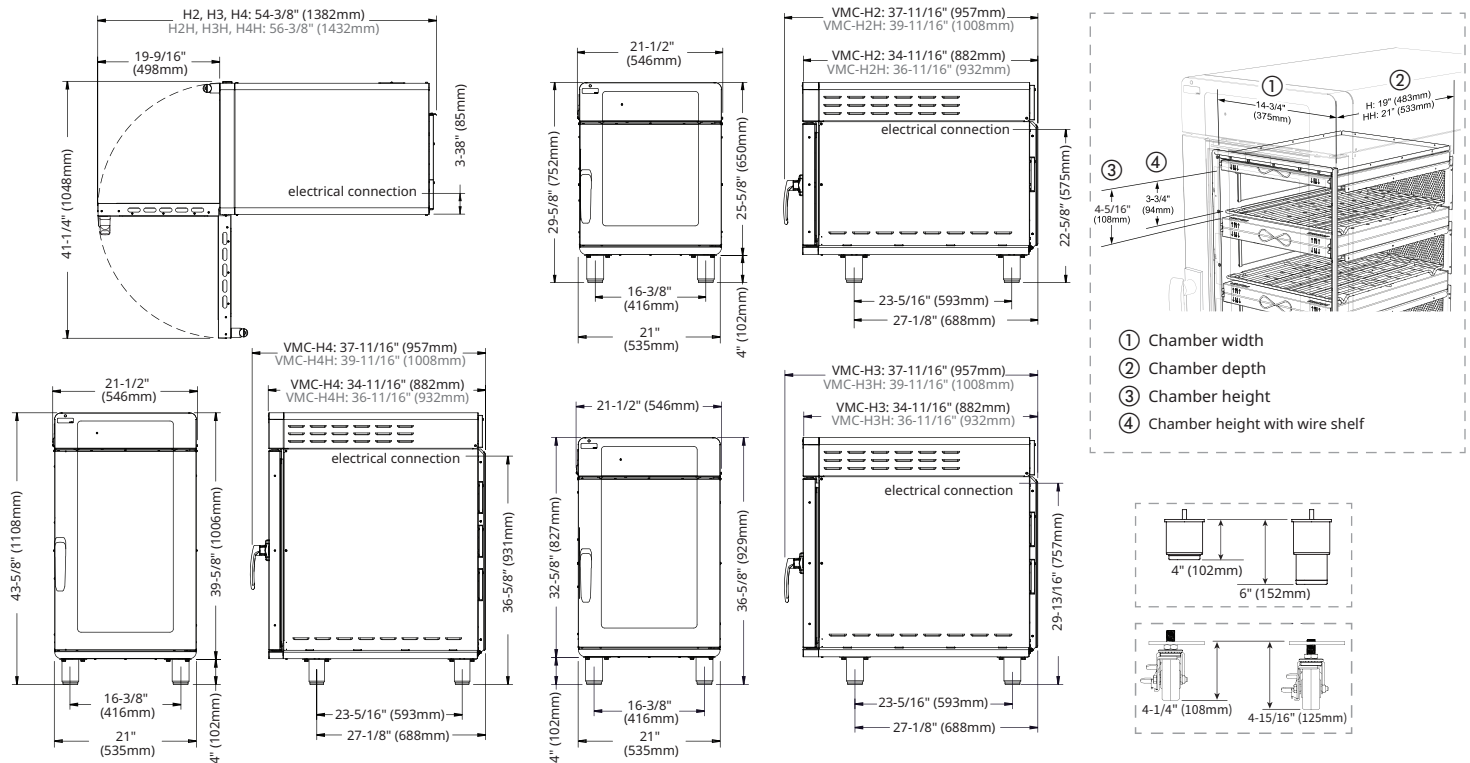

DIMENSIONS

Model	Exterior (H x W x D)	Interior (H x W x D)	Net Weight
VMC-H2	29-5/8" x 21-1/2" x 37-1/2" [752mm x 546mm x 953mm]	14-3/8" x 14-11/16" x 19" [366mm x 373mm x 483mm]	211 lb [96 kg]
VMC-H2H	29-5/8" x 21-1/2" x 39-1/2" [752mm x 546mm x 1003mm]	14-3/8" x 14-11/16" x 21-1/2" [366mm x 373mm x 546mm]	226 lb [103 kg]
VMC-H3	36-5/8" x 21-1/2" x 37-1/2" [929mm x 546mm x 953mm]	21-3/8" x 14-11/16" x 19" [544mm x 373mm x 483mm]	269 lb [122 kg]
VMC-H3H	36-5/8" x 21-1/2" x 39-1/2" [929mm x 546mm x 1003mm]	21-3/8" x 14-11/16" x 21-1/2" [544mm x 373mm x 546mm]	290 lb [131 kg]
VMC-H4	43-5/8" x 21-1/2" x 37-1/2" [1108mm x 546mm x 953mm]	28-3/8" x 14-11/16" x 19" [721mm x 373mm x 483mm]	341 lb [155 kg]
VMC-H4H	43-5/8" x 21-1/2" x 39-1/2" [1108mm x 546mm x 1003mm]	28-3/8" x 14-11/16" x 21-1/2" [721mm x 373mm x 546mm]	356 lb [161 kg]

Model	Ship Dimensions (L x W x H)*	Ship Weight*
VMC-H2/H	48" x 30" x 56" [1219mm x 762mm x 1422mm]	H2: 290 lb [132kg] H2H: 330 lb [150 kg]
VMC-H3/H	48" x 30" x 56" [1219mm x 762mm x 1422mm]	H3: 358 lb [162 kg] H3H: 364 lb [165 kg]
VMC-H4/H	48" x 30" x 56" [1219mm x 762mm x 1422mm]	H4: 418 lb [190 kg] H4H: 436 lb [198 kg]

*Domestic ground shipping information. Contact factory for export weight and dimensions.

Vector® H Series Multi-Cook Oven



Top: 2" [51mm]*
 Left: 2" [51mm]
 Right: 2" [51mm]
 Front: 20" [508mm]
 Back: 2" [51mm]

* 18" [457mm] recommended for service access



CHECK FIRST

- The oven must be installed level.
- The oven must not be installed in any area where it may be affected by steam, grease, dripping water, high temperatures, or any other severely adverse conditions.
- Oven not intended for built-in installation.



HEAT

Heat of rejection

VMC-H	Heat Gain qs, BTU/hr	Heat Gain qs, kW
	1,898	0.56



TEMPERATURE

Maximum temperature: 525°F [274°C]



ELECTRIC

VMC-H2/VMC-H2H	V	Ph	Hz	Awg	IEC	A	Breaker [A]	kW	Plug Configuration**	Certification
208-240V	208	1	60	8	—	25	30*	5.2	NEMA 6-30	
	240	1	60	8	—	28	30*	6.7	NEMA 6-30	
220-240V	220	1	50/60	—	4	25	32*	5.4	No cord, no plug	
	240	1	50/60	—	4	28	32*	6.4	No cord, no plug	
380-415V	380	3	50/60	—	1.5	8	16	5.4	No cord, no plug	
	415	3	50/60	—	1.5	9	16	6.4	No cord, no plug	
VMC-H3/VMC-H3H										
208-240V	208	1	60	6	—	38	50*	7.9	NEMA 6-50	
	240	1	60	6	—	43	50*	10.3	NEMA 6-50	
208-240V	208	3	60	10	—	22	30	7.9	NEMA 15-30P	
	240	3	60	10	—	25	30	10.3	NEMA 15-30P	
220-240V	220	1	50/60	6	10	37	63	8.1	No cord, no plug	
	240	1	50/60	6	10	41	63	9.6	No cord, no plug	
380-415V	380	3	50/60	—	1.5	13	16	8.1	No cord, no plug	
	415	3	50/60	—	1.5	14	16	9.6	No cord, no plug	
VMC-H4/VMC-H4H										
208-240V	208	3	60	6	—	32	40	10.6	NEMA 15-50P	
	240	3	60	6	—	36	40	13.9	NEMA 15-50P	
380-415V	380	3	50/60	—	4	17	32	10.8	No cord, no plug	
	415	3	50/60	—	4	18	32	12.7	No cord, no plug	

Electrical connections must meet all applicable federal, state, and local codes.

* For use on individual branch circuit only.

** No cord, no plug, in Canada.

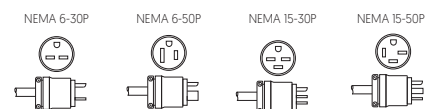

Vector® H Series Multi-Cook Oven



Stacked Configurations and Stands

VMC-H on stand 5034115

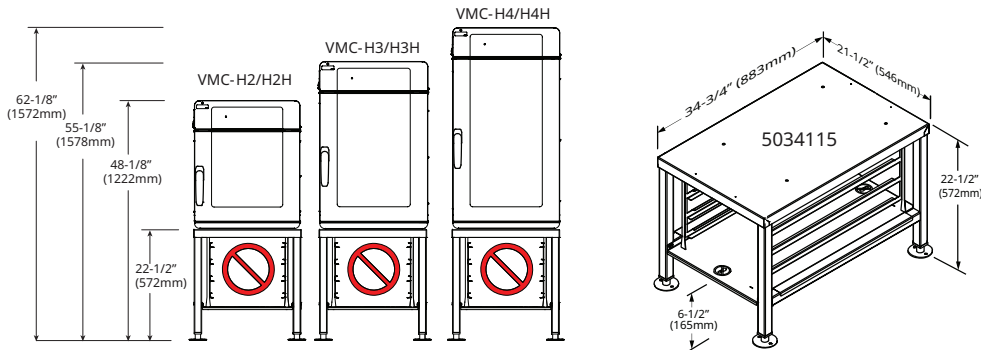

Dimensions shown are with adjustable feet at minimum height.

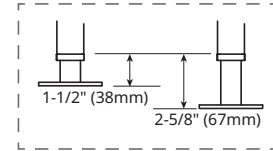

VMC-H on stand 5034118

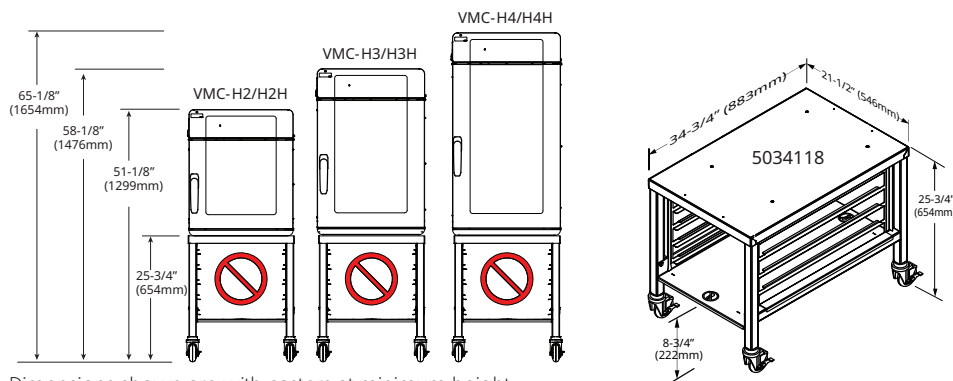

Dimensions shown are with casters at minimum height.

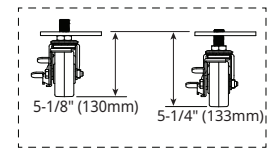

VMC-H on stand 5034294

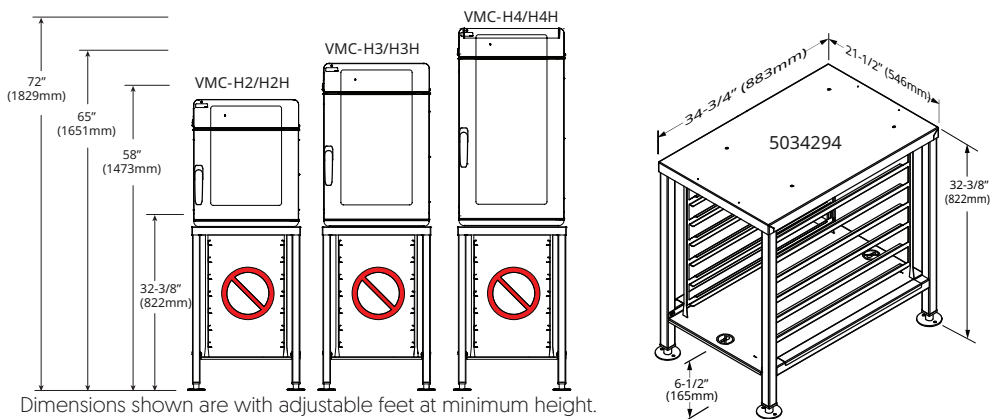

Dimensions shown are with adjustable feet at minimum height.

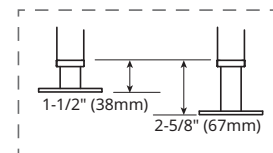

Scan or click the QR code for Vector stands guide

Vector® H Series Multi-Cook Oven



Stacked Configurations and Stands

VMC-H on stand 5033311 over
VMC-H3 or VMC-H3H with casters

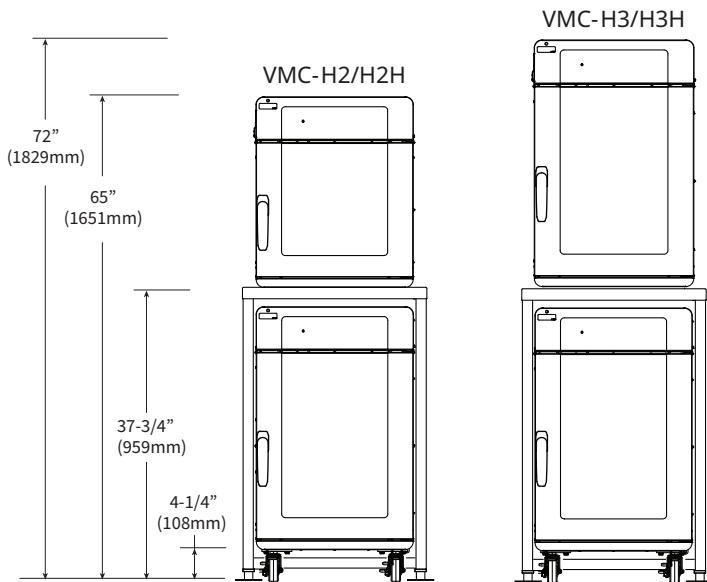

Dimensions shown are with adjustable feet at minimum height.

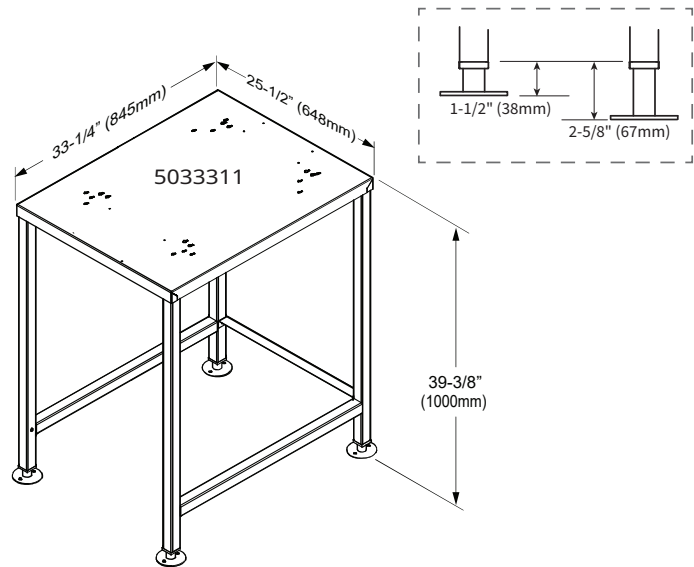

Other Bottom Unit Options

300-TH, 500-S, 500-TH, 500-IDN, 500-2DN, 500-3DN, VMC-H2/H2H

VMC-H on stand 5033314 over
VMC-H4 or VMC-H4H with casters

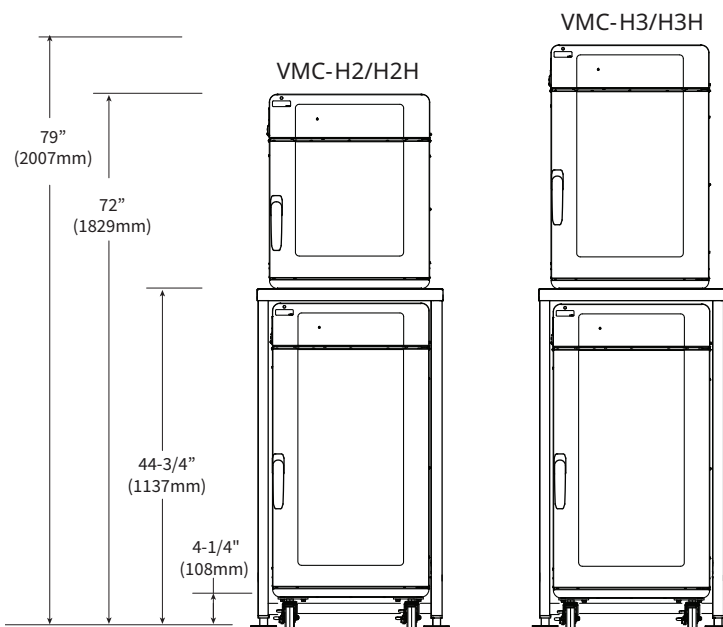

Dimensions shown are with adjustable feet at minimum height.

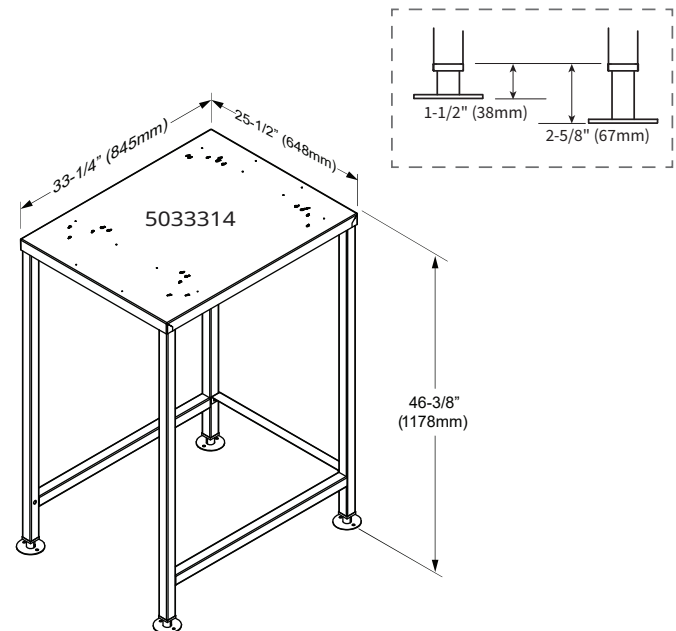

Other Bottom Unit Options

300-TH; 500-S; 500-TH; 500-IDN; 500-2DN; 500-3DN; VMC-H2/H2H;
VMC-H3/H3H



Scan or click the QR code
for Vector stands guide

Vector® H Series Multi-Cook Oven



Alternative Stacked Configurations and Stands

VMC-H on stand 5033317 over VMC-H3 or VMC-H3H

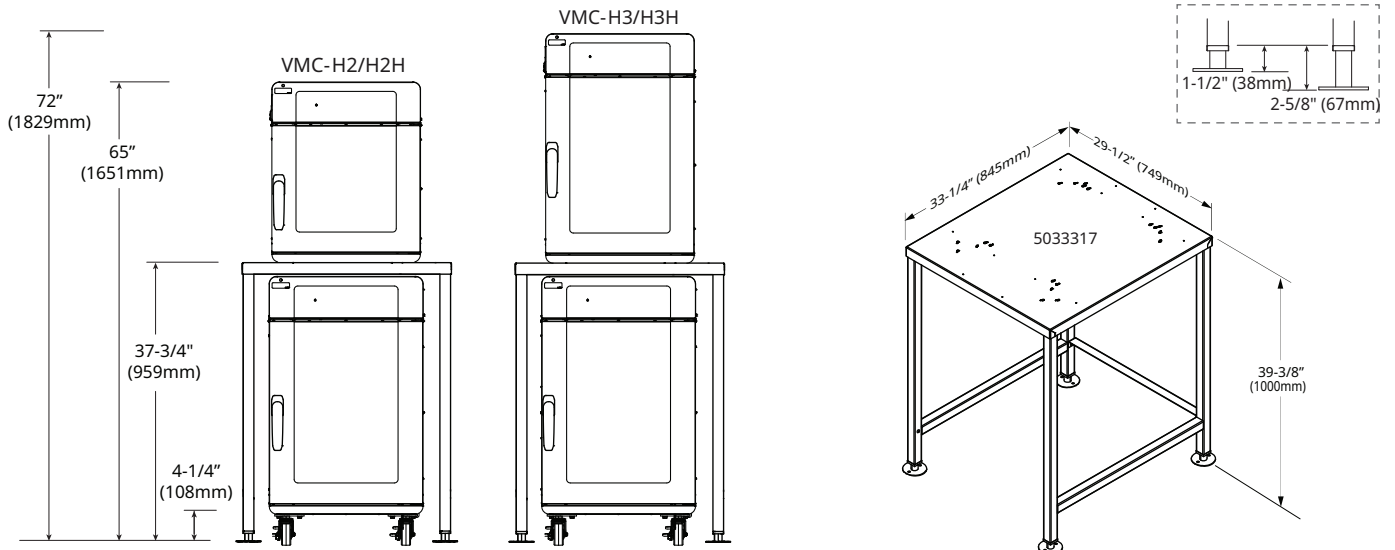

Dimensions shown are with adjustable feet at minimum height.

Other Bottom Unit Options

300-TH, 500-S*, 500-TH, 750-TH, 750-S**, 500-ID, 500-2D, 500-3D, 500-2DI, 500-IDN, 500-2DN, 500-3DN, VMC-H2/H2H, VMC-H2HW

*Smoker models must be under a hood.

**Excluding ovens with 5" [127mm] casters

VMC-H on stand 5033384 over VMC-H2, VMC-H2H, or VMC-H2HW

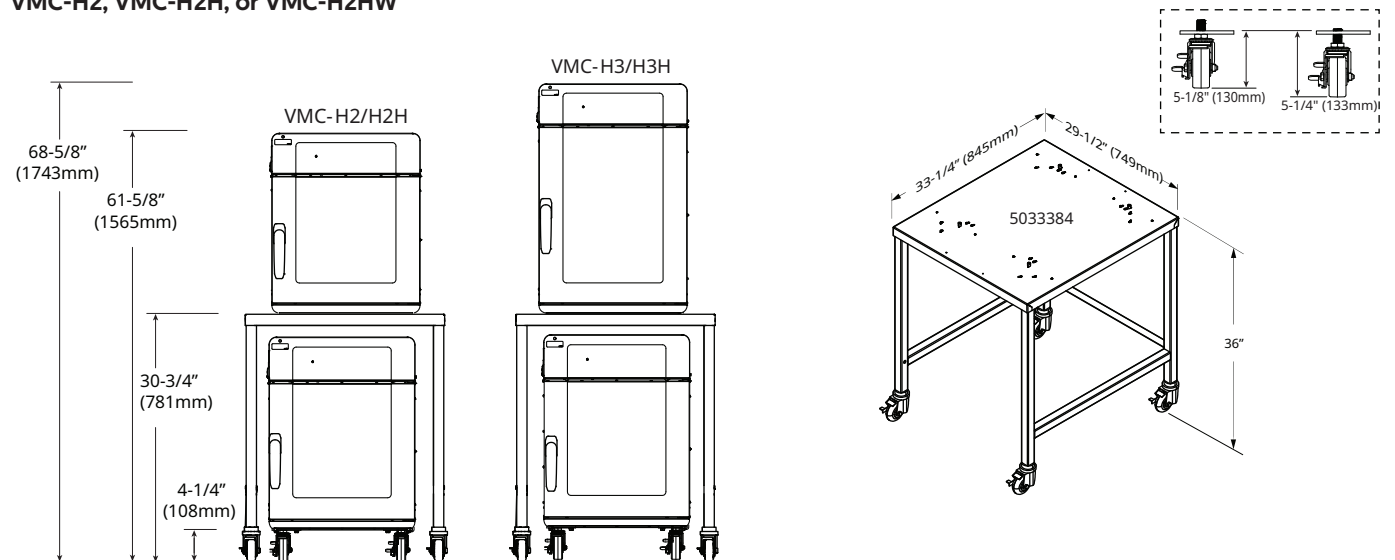

Dimensions shown are with casters at minimum height.

Other Bottom Unit Options

300-TH, 500-S*, 500-TH, 750-TH, 750-S**, 500-ID, 500-2D, 500-3D, 500-2DI, 500-IDN, 500-2DN, 500-3DN

*Smoker models must be under a hood.

**Excluding ovens with 5" [127mm] casters



Scan or click the QR code for Vector stands guide

Vector® H Series Multi-Cook Oven



Alternative Stacked Configurations and Stands

VMC-H on stand 5033479 over 500-TH

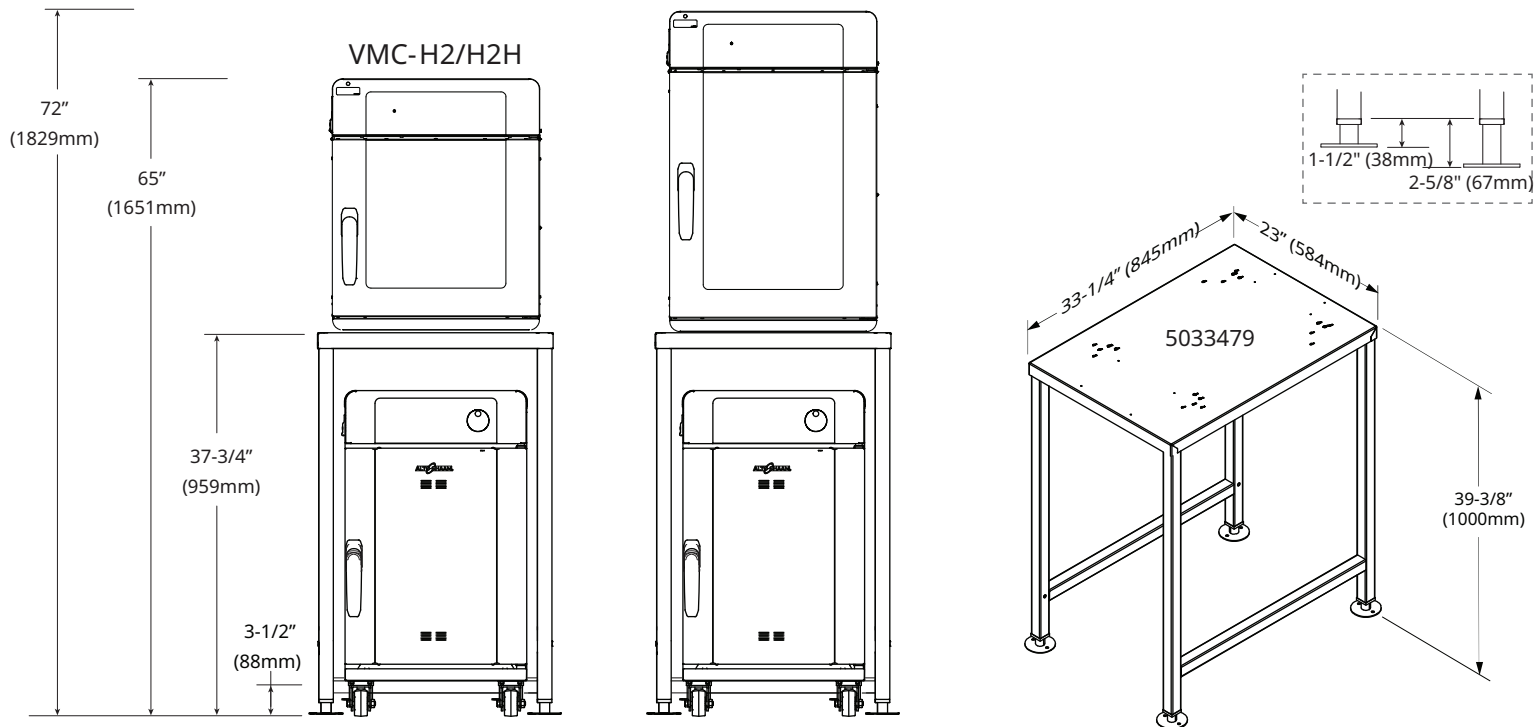

Dimensions shown are with adjustable feet at minimum height.

Other Bottom Unit Options

300-TH, 500-S, 500-TH, 500-IDN, 500-2DN, 500-3DN

CTX4-10 on stand 5033312 over VMC-H3 or VMC-H3H

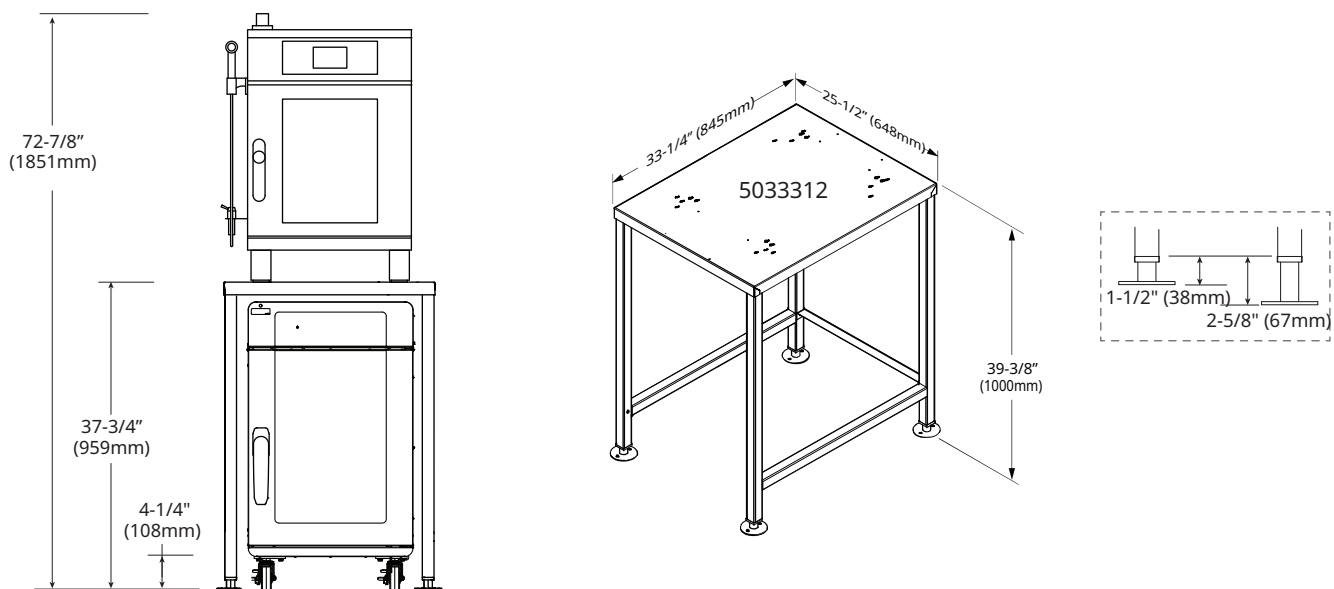

Dimensions shown are with adjustable feet at minimum height.

Other Bottom Unit Options

300-TH, 500-S, 500-TH, 500-IDN, 500-2DN, 500-3DN, VMC-H2/H2H

CONTACT US

W164 N9221 Water Street | Menomonee Falls, Wisconsin 53051 | U.S.A.
 Phone: 262.251.3800 | 800.558.8744 U.S.A./Canada | Fax: 262.251.7067 | alto-shaam.com