

IF-40

40 LB Fryer

The Inferno fryer features cast iron burners that provide even heat distribution across a large area. Its durable temperature probe quickly responds to temperature changes, providing a quick recovery time. Operating temperatures range from 200°F to 400°F with a millivolt safety control system. A large cold zone allows sediment to be easily separated out, maintaining oil quality and life span.



Features

- Cast iron burners
- Stainless steel tank
- Durable temperature probe
- Quick recovery time
- Operating temperatures from 200°F to 400°F
- Safety valve with automatic voltage stabilizing function
- Large cool zone to extend oil life
- Available in natural gas or liquid propane
- 1 year parts and labour warranty

IF-40

40 LB Fryer

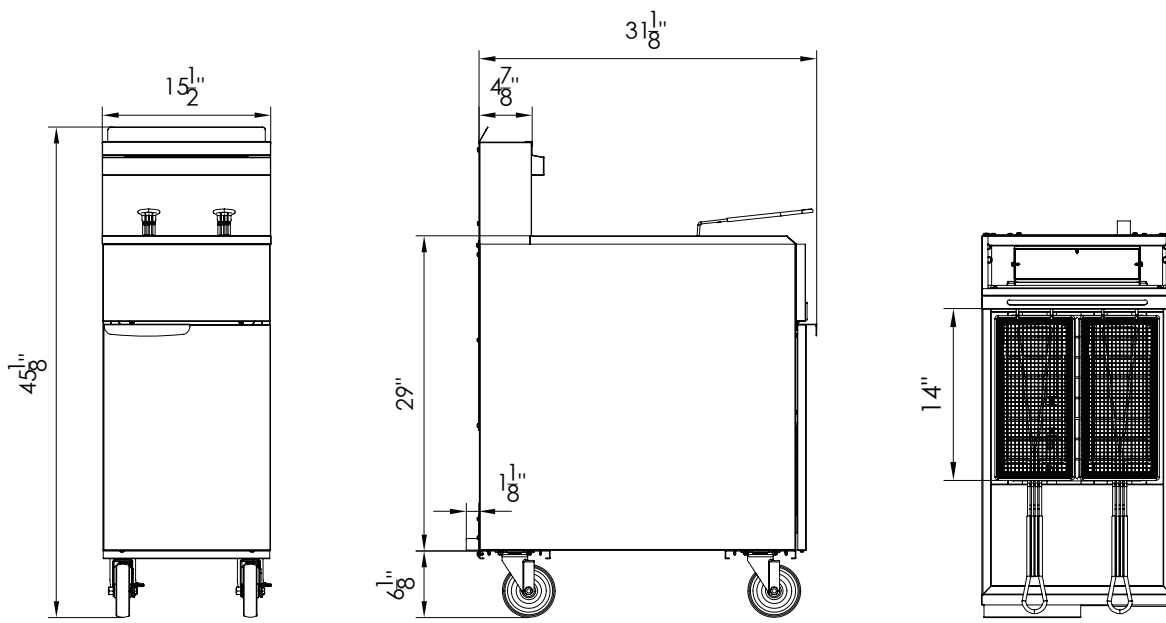

FRONT

LEFT

TOP

Model	External Dimensions (inches)			Crated Dimensions (inches)			Net Weight	Gross Weight	Gas Source	Burner Count	Single Burner	Total Output (BTU)	Orifice Size	Gas Pressure	Oil Tank Capacity
	W	D	H	W	D	H									
IF-40	15 1/2	32 7/8	45 1/8	17 7/8	35 3/8	37 5/8	165.35	187.39	LPG	3	30000	90000	52	10 in. WC	40
									NAT	3	30000	90000	39	4 in. WC	40

Specifications are subject to change without notice.