

IHP-6

36" (6) Open Burner Hot Plate

The Inferno hot plate is constructed with heavy duty stainless steel, cast iron grates and 28,000 BTU liftoff anti-clogging cast iron burners. All hot plates come standard in natural gas and are field convertible to liquid propane with the included conversion kit.



Features

- Six 28,000 BTU/hr burners
- Anti-clogging lift-off cast iron burners
- Full length removable crumb tray
- Shielded pilot light to protect from spills
- Natural gas standard
- Liquid propane conversion kit included
- 1 year parts and labour warranty

IHP-6

36" (6) Open Burner Hot Plate

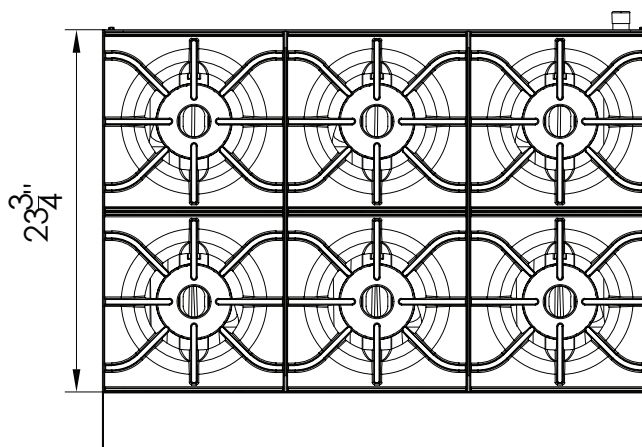

TOP

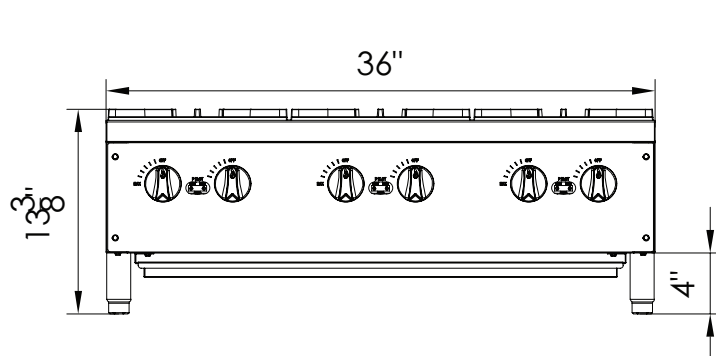

FRONT

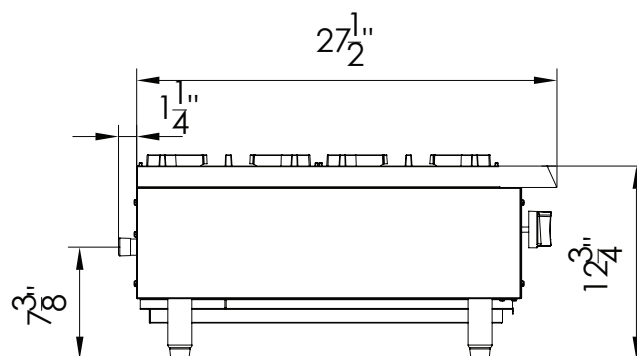

LEFT

Model	External Dimensions (inches)			Crated Dimensions (inches)			Net Weight	Gross Weight	Gas Source	Burner Count	Single Burner	Total Output (BTU)	Orifice Size	Gas Pressure
	W	D	H	W	D	H								
IHP-6	36	28 3/4	13 3/8	38 1/4	32 5/8	17 3/4	154.32	209.44	LPG	6	28000	168000	52	10 in. WC
									NAT	6	28000	168000	40	4 in. WC

Specifications are subject to change without notice.